



**SANTALUZIA®**

SUSTENTABILIDADE POR PRINCÍPIO

Sustainability by principle | Sustentabilidad por principio



# Santa Luzia: Sustentabilidade por princípio

Sustainability by principle | Sustentabilidade por princípio





Vivemos uma nova era. Uma era em que se torna urgente e imprescindível a ressignificação de posturas socioambientais em processos de produção. Nesse mesmo contexto, um número cada vez maior de indivíduos deseja fazer parte de um movimento de transformação global, repensando seus papéis como consumidores ou como profissionais dos mercados em que atuam.

Nos últimos 15 anos, temos aceitado o desafio de encontrar soluções economicamente viáveis e responsáveis com o meio ambiente. Investimos em pesquisa e desenvolvimento para construir 7 unidades de reciclagem em Braço do Norte, Santa Catarina e outros estados com capacidade para recuperar mais de 1000 toneladas de resíduos por mês.

Além de contribuir para reduzir os impactos da degradação ambiental por meio da reciclagem de resíduos, a Santa Luzia conseguiu dar um salto com seu modelo comercial. Porque produtos feitos de material reciclado possuem atributos cada vez mais valorizados pelas atuais e futuras gerações, que acreditam em sua responsabilidade e compromissos para a construção de um bem maior.

*We are living a new era. An era in which it becomes urgent and essential the re-signification of socio-environmental positions in production processes. In this same context, an increasing number of individuals wish to be part of a global transformation movement, rethinking their roles as consumers or as professionals in the markets in which they operate.*

*In the last 15 years, we have accepted the challenge of finding economically viable and responsible solutions with the environment. We invested in research and development to build 7 recycling facilities in Braço do Norte, Santa Catarina and other states with the capacity to recover more than 1000 tons of waste per month.*

*In addition to contributing to reduce the impacts of environmental degradation through waste recycling, Santa Luzia was able to make a jump with its commercial model. Since products made from recycled material have attributes that are increasingly valued by current and future generations, who believe in their responsibility and commitment to building a greater good.*

*Estamos viviendo una nueva era. Una era en la que se hace urgente y esencial la resignificación de las posiciones socio ambientales en los procesos de producción. En este mismo contexto, cada vez más personas desean formar parte de un movimiento de transformación global, reconsiderando sus roles como consumidores o como profesionales en los mercados en que los operan.*

*En los últimos 15 años, hemos aceptado el desafío de encontrar soluciones económicamente viables y responsables con el medioambiente. Invertimos en investigación y desarrollo para construir 7 instalaciones de reciclaje en Braço do Norte, Santa Catarina y otros estados con la capacidad de recuperar más de 1000 toneladas de desechos por mes.*

*Además de contribuir a reducir los impactos de la degradación ambiental a través del reciclaje de residuos, Santa Luzia pudo dar un salto con su modelo comercial. Dado que los productos hechos de material reciclado tienen atributos que son cada vez más valorados por las generaciones actuales y futuras, que creen en su responsabilidad y compromiso para construir un bien mayor.*

## Impactos positivos no meio ambiente

Positive impacts on the environment | Impactos positivos en el medio ambiente

- Já reciclamos o equivalente a 83 mil carretas de resíduos como o EPS (Isopor®) e o poliuretano. Um modelo de desenvolvimento que causa um impacto positivo real na natureza.
- Ao desenvolver nossos produtos com matéria-prima 100% reciclada, deixamos de derrubar mais de 893 mil árvores.
- Santa Luzia já acumula o correspondente a 1624 campos de futebol de resíduos transformados em matéria-prima para produtos de design e decoração.
- Em nosso parque fabril, a matéria-prima descartada durante a produção é reincorporada ao processo, criando um ciclo infinito de reaproveitamento que não causa danos ao meio ambiente.

*• We have already recycled the equivalent of 83 thousand waste carts of residues such as EPS and polyurethane. A development model that has a real positive impact on nature.*

*• By developing our products with 100% recycled raw material, we stopped overthrowing more than 893 thousand trees.*

*• Santa Luzia already accumulates the corresponding to 1624 soccer fields of waste transformed into raw material for design and decoration products.*

*• In our factory, the raw material discarded during production is reincorporated into the process, creating an infinite cycle of reuse that does not cause damage to the environment.*

*• Ya hemos reciclado el equivalente a 83 mil carretas de residuos como EPS y poliuretano. Un modelo de desarrollo que tiene un impacto positivo real en la naturaleza.*

*• Al desarrollar nuestros productos con materia prima 100% reciclada, dejamos de cortar más de 893 mil árboles.*

*• Santa Luzia ya acumula el equivalente a 1624 campos de fútbol de desechos transformados en materia prima para productos de diseño y decoración.*

*• En nuestra fábrica, la materia prima descartada durante la producción se reincorpora al proceso, creando un ciclo infinito de reutilización que no causa daños al medio ambiente.*



# Por que a Santa Luzia é a sua melhor escolha?

Why Santa Luzia is your best choice?  
¿Por qué Santa Luzia es tu mejor opción?



## Fabricação responsável

A Santa Luzia se preocupa com o desenvolvimento sustentável do planeta, por isso buscamos constantemente a otimização de nossos produtos e processos em busca de melhorar nosso desempenho ambiental. O uso de matéria-prima reciclada foi uma estratégia que encontramos para contribuir com a redução de descarte de poliestireno em aterros sanitários.

### Responsible Manufacturing

Santa Luzia is concerned with the planet sustainable development; therefore, we are constantly seeking to optimize our products and processes in order to improve our environmental performance. The use of recycled raw materials was a strategy that we found to contribute with the reduction of polystyrene disposal in landfills.

### Fabricación Responsable

Santa Luzia se preocupa por el desarrollo sostenible del planeta; por lo tanto, estamos constantemente buscando optimizar nuestros productos y procesos para mejorar nuestro desempeño ambiental. El uso de materias primas recicladas fue una estrategia que encontramos para contribuir con la reducción de la eliminación de poliestireno en vertederos.

## Conteúdo reciclado e reciclável

Nossos perfis são fabricados com 96% de poliestireno reciclado e são 100% recicláveis.

### Recycled and Recyclable Content

Our profiles are manufactured with 96% recycled polystyrene and are 100% recyclable.

### Contenido reciclado y reciclable

Nuestros perfiles están fabricados con 96% de poliestireno reciclado y son 100% reciclables.

## Logística Reversa

A Santa Luzia oferece e encoraja os clientes a enviarem sobras de instalação e descarte dos perfis de poliestireno para que possamos utilizar novamente no processo produtivo, pois o produto é 100% reciclável.

### Reverse Logistics

Santa Luzia offers and encourages customers to send back leftovers from the installation and disposal of polystyrene profiles in order to use them again in the production process, since the product is 100% recyclable.

### Logística Inversa

Santa Luzia ofrece y alienta a los clientes a que envíen de vuelta los restos de la instalación y eliminación de perfiles de poliestireno para que podamos volver a utilizarlos en el proceso de producción, ya que el producto es 100% reciclable.

## Baixo VOC

Entendemos que materiais saudáveis contribuem para a qualidade de vida das pessoas que ocupam os ambientes. Nossos perfis foram testados e aprovados de acordo com o Departamento de Saúde Pública da Califórnia (CDPH), norma V1.1 (2010). Por isso contribuem para pontuação em projetos LEED na categoria de Qualidade do Ambiente Interno.

### INFORMAÇÕES: COV - COMPOSTOS ORGÂNICOS VOLÁTEIS

Produto   Product   Producto	COV
Perfis de Poliestireno Polystyrene Profiles   Perfiles de poliestireno	COV = 2,87 g/L
Cola Santa Luzia Santa Luzia Glue   Pegamento Santa Luzia	COV = 4,95 g/L
Super Adesivo Santa Luzia Heavy Duty Adhesive   Super Pegatina	COV = 37 g/L
Calafetador Santa Luzia Caulk   Calafeteador	COV = 82 g/L
Massa Premium Santa Luzia Caulk Santa Luzia   Masilla Santa Luzia	COV = 0,88 g/L

### Low VOC

We understand that healthy materials contribute to life quality of environments occupants. Our profiles have been tested and approved according to the California Department of Public Health (CDPH), standard V1.1 (2010). For that reason, they contribute to score in LEED projects in the category of Indoor Environmental Quality.

### Bajo VOC

Entendemos que los materiales sustentables contribuyen a la calidad de vida de los ocupantes del entorno. Nuestros perfiles han sido probados y aprobados de acuerdo con el Departamento de Salud Pública de California (CDPH), estándar V1.1 (2010). Por esa razón, contribuyen a obtener puntajes en proyectos LEED en la categoría de Calidad Ambiental Interior.



## Construções Sustentáveis

Nossa linha de perfis de poliestireno contribui para a pontuação na Certificação LEED V4, nas categorias de Materiais e Recursos, Qualidade do Ambiente Interno, Materiais Regionais e Inovação.

### SUSTAINABLE CONSTRUCTIONS

Our line of polystyrene profiles contributes to the LEED V4 Certification Scoring in the categories of: Materials and Resources, Indoor Environmental Quality, Regional Materials and Innovation.

### CONSTRUCCIONES SUSTENTABLES

Nuestra línea de perfiles de poliestireno contribuye al puntaje de certificación LEED V4 en las categorías de: Materiales y Recursos, Calidad Ambiental Interior, Materiales Regionales e Innovación.



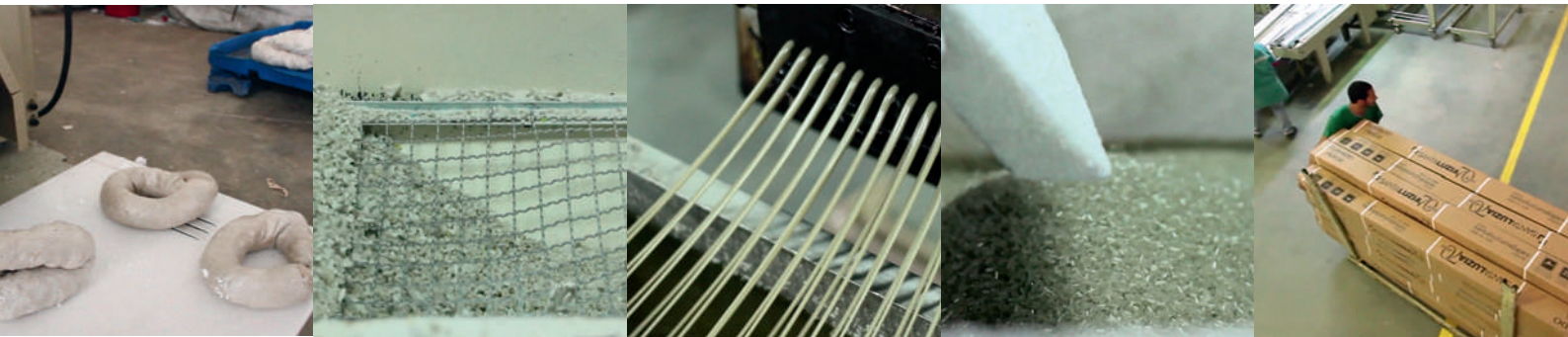

## Economia Circular

Ao lado de outras grandes empresas líderes em pensamento global, a Santa Luzia amplia suas ambições para contribuir com a transição para a economia circular através do seu modelo de negócio com foco em reutilização de materiais.



### 1 - Refinaria

Refinery/Refinería

### 2 - Petroquímica

Petrochemicals/Petroquímicos

### 3 - Indústria de Transformação

Manufacturing Industry/Industria Manufacturera

### 4 - Indústria Consumidora

Consumer Industry/Industria del Consumidor

### 5 - Consumidor final

Final consumer/Consumidor final

### 6 - Coleta Seletiva

Selective Collection/Colectión selectiva

### 7 - Cooperativas

Cooperatives/ Cooperativas

### 8 - Santa Luzia

#### Circular Economy

Alongside other leading companies in global thinking, Santa Luzia extends its ambitions to contribute to the transition for a circular economy through its business model focused on material reuse.

#### Economía Circular

Junto con otras empresas líderes en pensamiento global, Santa Luzia amplía sus ambiciones de contribuir a la transición hacia una economía circular a través de su modelo de negocios enfocado en la reutilización de materiales.



## EPD

Nossa Declaração Ambiental de Produto (Environmental Product Declaration) demonstra de forma clara e transparente os impactos ambientais relacionados ao produto em cada etapa do seu ciclo de vida. Por meio dessa ferramenta, os fabricantes permitem que os clientes ou especificadores estejam aptos a decidir pela compra de um ou outro produto com base nessas informações. Uma importante ferramenta que vem sendo difundida no Brasil, a EPD ou DAP fornece informações relevantes com base na Avaliação de Ciclo de Vida.

EPD - Our Environmental Product Declaration clearly and transparently demonstrates the environmental impacts related to the product at each stage of its life cycle. Through this tool, manufacturers allow customers or specifiers to decide to purchase one or another product based on this information. An important tool that is being disseminated in Brazil, the EPD provides relevant information based on the Life Cycle Assessment.

EPD - Nuestra Declaración Ambiental de Producto (Environmental Product Declaration) demuestra clara y transparentemente los impactos ambientales relacionados con el producto en cada etapa de su ciclo de vida. A través de esta herramienta, los fabricantes permiten que los clientes o los especificadores decidan comprar uno u otro producto en base a esta información. Una herramienta importante que se está diseminando en Brasil, el EPD proporciona información relevante basada en la evaluación del ciclo de vida.

## Sociedade



Por meio de participação em projetos de educação ambiental de algumas empresas parceiras, várias crianças recebem o programa de conscientização sobre a importância da preservação do meio ambiente e da correta destinação dos resíduos gerados por eles.

#### Society

Through participation in environmental education projects of some partner companies, several children receive the awareness program about the importance of preserving the environment and the correct destination of the waste generated by them.

#### Sociedad

A través de la participación en proyectos de educación ambiental de algunas empresas asociadas, varios niños reciben el programa de concientización sobre la importancia de preservar el medio ambiente y el destino correcto de los desechos generados por ellos.

Produto | Product | Producto

① 464 RP/BR

② 444 RP/BR

③ 466 RM/BR





Discrição pode dar um novo ar ao ambiente. A sua residência ou seu escritório, vai ganhar um toque de charme e elegância com os produtos da linha moderna.

*Discretion can give a new look to the ambient. Your residence or office will have a touch of charm and elegance with the products of this line.*

*La discreción puede dar una nueva imagen al ambiente. Su casa o su oficina van a ganar un toque de encanto y elegancia con los productos de esta línea.*

## Rodapés | Skirting Boards | Zócalos

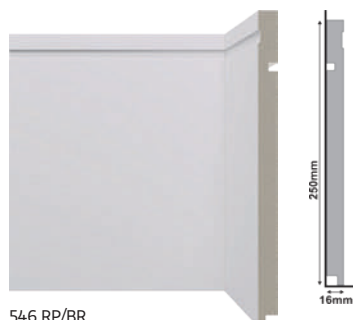

**546 RP/BR**  
Skirting Board White | Zócalo Blanco  
Cód. | Code - 27857



**505 RP/BR**  
Skirting Board White | Zócalo Blanco  
Cód. | Code - 25954



**506 RP/BR**  
Skirting Board White | Zócalo Blanco  
Cód. | Code - 25955



**461 RP/BR**  
Skirting Board White | Zócalo Blanco  
Cód. | Code - 20247



**480 RP/BR**  
Skirting Board White | Zócalo Blanco  
Cód. | Code - 20299

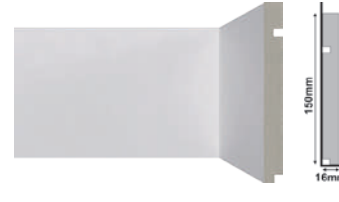

**496 RP/BR**  
Skirting Board White | Zócalo Blanco  
Cód. | Code - 24899



**502 RP/BR**  
Skirting Board White | Zócalo Blanco  
Cód. | Code - 25426



**503 RP/BR**  
Skirting Board White | Zócalo Blanco  
Cód. | Code - 25427



**513 RP/BR**  
Skirting Board White | Zócalo Blanco  
Cód. | Code - 26674



**515 RP/BR**  
Skirting Board White | Zócalo Blanco  
Cód. | Code - 26675



**493 RP/BR**  
Skirting Board White | Zócalo Blanco  
Cód. | Code - 24574



**454 RP/BR**  
Skirting Board White | Zócalo Blanco  
Cód. | Code - 20232

## Rodapés | Skirting Boards | Zócalos



**457 RP/BR**  
Skirting Board White | Zócalo Blanco  
Cód. | Code - 20239



**460 RP/BR**  
Skirting Board White | Zócalo Blanco  
Cód. | Code - 20245



**464 RP/BR**  
Skirting Board White | Zócalo Blanco  
Cód. | Code - 20252



**512 RP/BR**  
Skirting Board White | Zócalo Blanco  
Cód. | Code - 26657



**514 RP/BR**  
Skirting Board White | Zócalo Blanco  
Cód. | Code - 26656



**547 RP/BR**  
Skirting Board White | Zócalo Blanco  
Cód. | Code - 27858



**550 RP/BR**  
Skirting Board White | Zócalo Blanco  
Cód. | Code - 27860



**565 RP/BR**  
Skirting Board White | Zócalo Blanco  
Cód. | Code - 28751



**446 RP/BR**  
Skirting Board White | Zócalo Blanco  
Cód. | Code - 20013



**451 RP/BR**  
Skirting Board White | Zócalo Blanco  
Cód. | Code - 20229



**456 RP/BR**  
Skirting Board White | Zócalo Blanco  
Cód. | Code - 20237



**459 RP/BR**  
Skirting Board White | Zócalo Blanco  
Cód. | Code - 20243



**441 RP/BR**  
Skirting Board White | Zócalo Blanco  
Cód. | Code - 20003



**455 RP/BR**  
Skirting Board White | Zócalo Blanco  
Cód. | Code - 20234



**466 RP/BR**  
Skirting Board White | Zócalo Blanco  
Cód. | Code - 20255



**473 RP/BR**  
Skirting Board White | Zócalo Blanco  
Cód. | Code - 24545



**478 RP/BR**  
Skirting Board White | Zócalo Blanco  
Cód. | Code - 20297

Utilize Santa Luzia  
Massa Premium  
na cor BRANCA para um  
acabamento perfeito.  
Use Santa Luzia WHITE premium caulk  
for a perfect finish.  
Utilice Santa Luzia masilla BLANCA  
premium para un acabado perfecto.





Guarniões | Door Casings | Contramarcos

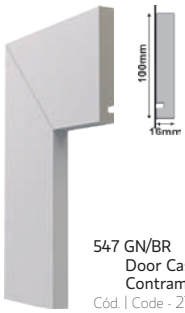

547 GN/BR  
Door Case White  
Contramarco Blanco  
Cód. | Code - 27859

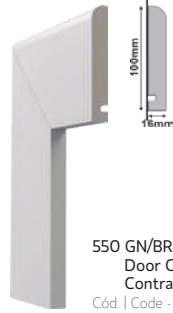

550 GN/BR  
Door Case White  
Contramarco Blanco  
Cód. | Code - 27861

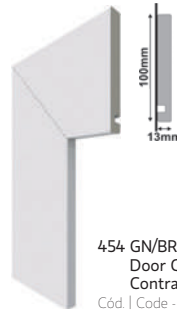

454 GN/BR  
Door Case White  
Contramarco Blanco  
Cód. | Code - 20233

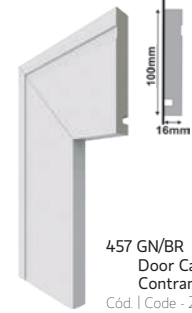

457 GN/BR  
Door Case White  
Contramarco Blanco  
Cód. | Code - 20240

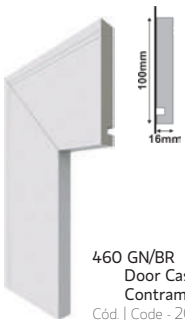

460 GN/BR  
Door Case White  
Contramarco Blanco  
Cód. | Code - 20246



512 GN/BR  
Door Case White  
Contramarco Blanco  
Cód. | Code - 26678



514 GN/BR  
Door Case White  
Contramarco Blanco  
Cód. | Code - 26679

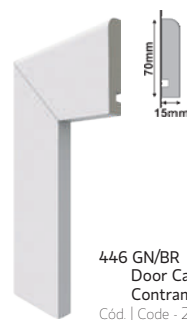

446 GN/BR  
Door Case White  
Contramarco Blanco  
Cód. | Code - 20021



451 GN/BR  
Door Case White  
Contramarco Blanco  
Cód. | Code - 20230



456 GN/BR  
Door Case White  
Contramarco Blanco  
Cód. | Code - 20238

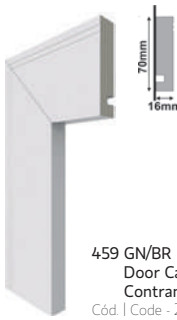

459 GN/BR  
Door Case White  
Contramarco Blanco  
Cód. | Code - 20244



455 GN/BR  
Door Case White  
Contramarco Blanco  
Cód. | Code - 20236

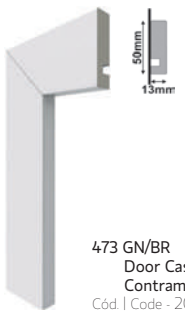

473 GN/BR  
Door Case White  
Contramarco Blanco  
Cód. | Code - 20398



478 GN/BR  
Door Case White  
Contramarco Blanco  
Cód. | Code - 20298

Regulável | Adjustable | Ajustable

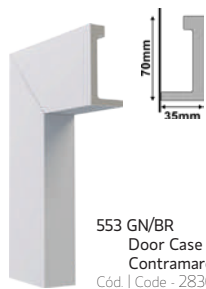

553 GN/BR  
Door Case White - Adjustable  
Contramarco Blanco - Ajustable  
Cód. | Code - 28369

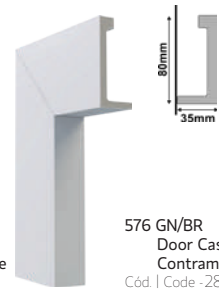

576 GN/BR  
Door Case White - Adjustable  
Contramarco Blanco - Ajustable  
Cód. | Code - 28369

Rodameio  
Chair Rail | Guardasilla



466 RW/BR  
Trim White | Guardasilla Blanco  
Cód. | Code - 20256

Rodatetos | Crown Mouldings | Cornisas



457 RT/BR  
Crown White | Cornisa Blanco  
Cód. | Code - 25787



441 RT/BR  
Crown White | Cornisa Blanco  
Cód. | Code - 25785

Produtos | Products | Productos

- ① 465 RM/BR
- ② 475 RT/BR
- ③ 443 RP/BR

# Linha Clássica

Classic Line | Línea Clásica

PRODUTO  
**SANTALUZIA**

Barras de 2,40m | 8ft bars

Opção ideal para quem faz questão de requinte e sofisticação. Com a Linha Clássica, você nunca vai ficar fora da moda.

*Ideal option for those who value refinement and sophistication. With the classic line, you will never go out of style.*

*Opción ideal para quien quiere un punto de refinamiento y sofisticación. Con la línea clásica usted nunca estará fuera de moda.*



## Rodapés | Skirting Boards | Zócalos



**01 RP/BR**  
Skirting Board White | Zócalo Blanco  
Cód. | Code - 20001



**443 RP/BR**  
Skirting Board White | Zócalo Blanco  
Cód. | Code - 20007



**444 RP/BR**  
Skirting Board White | Zócalo Blanco  
Cód. | Code - 20009



**442 RP/BR**  
Skirting Board White | Zócalo Blanco  
Cód. | Code - 20005

## Rodatetos | Crown Moulding | Cornisas



**01 RT/BR**  
Crown White | Cornisa Blanco  
Cód. | Code - 25784



**444 RT/BR**  
Crown White | Cornisa Blanco  
Cód. | Code - 25786



**475 RT/BR**  
Crown White | Cornisa Blanco  
Cód. | Code - 20294

## Guarniões | Door Casings | Contramarcos



**442 GN/BR**  
Door Case White  
Contramarco Blanco  
Cód. | Code - 20006



**443 GN/BR**  
Door Case White  
Contramarco Blanco  
Cód. | Code - 20008

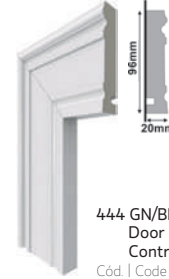

**444 GN/BR**  
Door Case White  
Contramarco Blanco  
Cód. | Code - 20010

## Rodameios | Chair Rails | Guardasillas



**467 RM/BR**  
Trim White | Guardasilla Blanco  
Cód. | Code - 20292



**465 RM/BR**  
Trim White | Guardasilla Blanco  
Cód. | Code - 20254



**448 RM/BR**  
Trim White | Guardasilla Blanco  
Cód. | Code - 20227

## Sócalos e Rosetas | Plinth Blocks and Rosettes | Sócalins y Rosetas

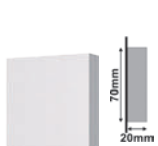

**Roseta 175** | Rosette | Roseta  
70 x 70 x 20mm  
Cód. | Code - 27380

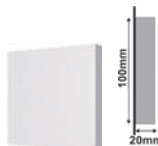

**Roseta 176** | Rosette | Roseta  
100 x 100 x 20mm  
Cód. | Code - 27375

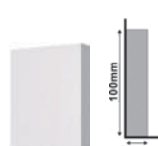

**Sócalo 177**  
Plinth Block | Zócalin  
80 x 100 x 20mm  
Cód. | Code - 27367

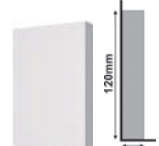

**Sócalo 178**  
Plinth Block | Zócalin  
80 x 120 x 20mm  
Cód. | Code - 27368

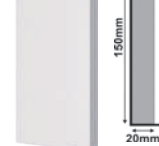

**Sócalo 183**  
Plinth Block | Zócalin  
70 x 150 x 20mm  
Cód. | Code - 27373

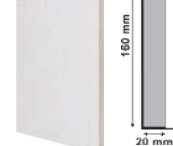

**Sócalo 187**  
Plinth Block | Zócalin  
110 x 160 x 20mm  
Cód. | Code - 27377

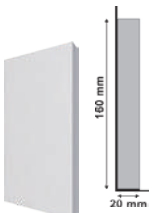

**Sócalo 186**  
Plinth Block | Zócalin  
80 x 160 x 20mm  
Cód. | Code - 27376



**Sócalo 179**  
Plinth Block | Zócalin  
80 x 220 x 20mm  
Cód. | Code - 27369

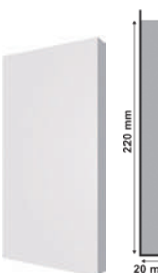

**Sócalo 181**  
Plinth Block | Zócalin  
110 x 220 x 20mm  
Cód. | Code - 27371



**Sócalo 180**  
Plinth Block | Zócalin  
110 x 240 x 20mm  
Cód. | Code - 27370



**Sócalo 182**  
Plinth Block | Zócalin  
110 x 270 x 20mm  
Cód. | Code - 27372



**Sócalo 188**  
Plinth Block | Zócalin  
110 x 310 x 20mm  
Cód. | Code - 27378

## Meia Curva | Half Round | Media Caña

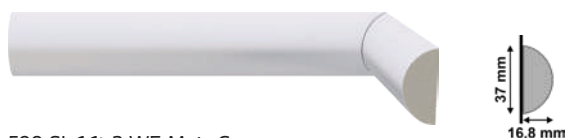

599 SL 11t-2 WE Meia Curva

559 SL 11-2 WE Half Round | 559 SL 11-2 WE Media Caña

Code: 22553



597 SL 5-8 WE Meia Curva

597 SL 5-8 WE Half Round | 597 SL 5-8 WE Media Caña

Code: 22554



598 SL 1 WE Meia Curva

598 SL 1 WE Half Round | 598 SL 1 WE Media Caña

Code: 22555

## Acabamento de rodapé

Quarter Round | Molduras de Sobreponer



468 SL 11-16 WE Acabamento para Rodapé

468 SL 11-16 WE Quarter Round | 468 SL 11-16 WE Molduras de sobreponer

Code: 22558



605 SL 13-16 WE Acabamento para Rodapé

605 SL 13-16 WE Baseboard | 605 SL 13-16 WE Molduras de sobreponer

Code: 22560

## Cantoneiras

Corner Guard | Esquineiro em L



604 SL 11-4 WE Cantoneira

604 SL 11-4 WE CornerGuard | 604 SL 11-4 WE Esquineiro em L

Code: 22556



603 SL 5-8 WE Cantoneira

603 SL 5-8 WE CornerGuard | 603 SL 5-8 WE Esquineiro em L

Code: 22557

## Arredondado

Quarter Round | Cuarta Caña

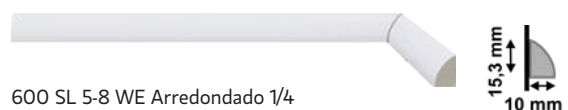

600 SL 5-8 WE Arredondado 1/4

600 SL 5-8 WE Quarter Round | 600 SL 5-8 WE Cuarta Caña

Code: 22561

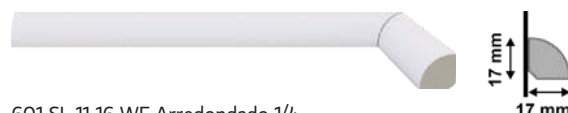

601 SL 11-16 WE Arredondado 1/4

601 SL 11-16 WE Quarter Round | 601 SL 11-16 WE Cuarta Caña

Code: 22562

## Borda arredondada

Round Edge | Tapajunta



606 SL 15-16 WE Borda Arredondado

606 SL 15-16 WE Round Edge | 606 SL 15-16 WE Tapajunta

Code: 22563

## Meia Cana | Cove | Rinconero



602 SL 5-8 WE Meia Cana

602 SL 5-8 WE Cove | 602 SL 5-8 WE Rinconero

Code: 22564



Produtos | Products | Productos

① 448 RM/BR

①



Produtos | Products | Productos

① KIT Guarnição 456

①





# Kit Guarnição

PRODUTO  
**SANTALUZIA**

Casing Pro Pack | Kit Contramarco

02 Barras de 2,20m e 01 barra de 1,10m | 02 bars of 2,20m and 01 bar of 1,10m

O Kit Guarnição da Indústria Santa Luzia foi desenvolvido para diminuir a geração de resíduos com guarnições ao criar molduras em portas/portais de ambientes internos. Evitando o desperdício, o Kit fornece dois perfis para laterais e um para o topo, cortados e acabados nas medidas de diferentes padrões de portas, de modo que você possa se concentrar somente na instalação!

*Santa Luzia's Casing Pro Pack was developed to reduce the waste of our casings by creating frames on indoor doors/portals. Avoiding waste, the Kit provides two profiles for the lateral sides of the door and one for the top, cut and finished to the dimensions of different door patterns, so that you can concentrate only on the installation!*

*El kit contramarco de la Industria de Santa Luzia se desarrolló para reducir la generación de desechos con recortes mediante la creación de marcos en puertas/portales para ambientes interiores. Evitando desperdicios, el Kit proporciona dos perfiles para los lados y uno para la parte superior, cortados y acabados a las dimensiones de diferentes patrones de puertas, para que pueda concentrarse solo en la instalación!*

## Produtos | Products | Productos

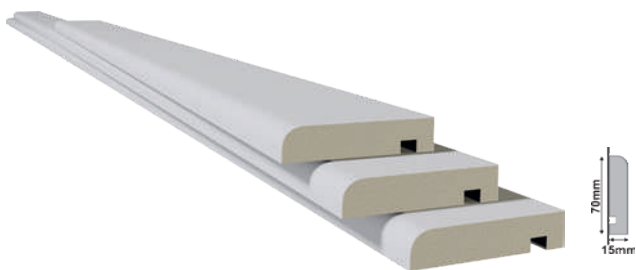

Kit Guarnição 446 Branco  
Door Case Pro Pack 446 White | Kit Contramarco 446 Blanco  
Cód. | Code - 20335



Kit Guarnição 446 Natural 04  
Door Case Pro Pack 446 Natural 04 | Kit Contramarco Natural 04  
Cód. | Code - 28906



Kit Guarnição 456 Branco  
Door Case Pro Pack 456 White | Kit Contramarco 456 Blanco  
Cód. | Code - 20681



Kit Guarnição 455 Branco  
Door Case Pro Pack 455 White | Kit Contramarco 455 Blanco  
Cód. | Code - 20680

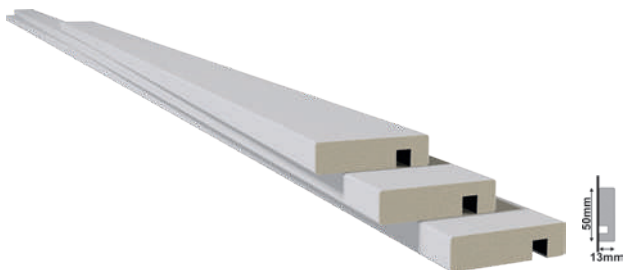

Kit Guarnição 473 Branco  
Door Case Pro Pack 473 White | Kit Contramarco 473 Blanco  
Cód. | Code - 28904

Utilize Santa Luzia  
Massa Premium  
para um acabamento  
perfeito.

Use Santa Luzia premium caulk for a  
perfect finish.

Utilice Santa Luzia masilla premium  
para un acabado perfecto.



## TODOS OS KITS ACOMPANHAM:

*Todos os Kits acompanham: / All the Pro Packs come along with:*

- 02 barras de 2,20 m e 01 barra de 1,10 m
- 14 buchas e 14 pregos
- Gabarito para marcação de 5 cm
- 02 bars of 2,20 m and 01 bar of 1,10 m
- 14 brackets and 14 nails
- Mounting model for 2" marking
- 02 barras de 2,20 m y 01 barra de 1,10 m
- 14 tarugos y 14 clavos
- Plantilla de montaje para marcado de 5 cm







1

2

Produtos | Products | Productos

① 467 RM/BR

② 448 RM/BR

# Coleção Boiseries

PRODUTO  
**SANTALUZIA**

Wall Paneling Collection | Colección Boiseries

Esta coleção traz peças únicas pré-fabricados, que podem ser utilizadas para criar painéis de parede para boiserie, adicionando elegância e beleza em qualquer ambiente

*This collection brings finished single pieces, wich can be used to create wall panels for Wall paneling/Boiseries, adding elegance and beauty in any rooms.*

*Esta colección trae piezas únicas prefabricadas, que se pueden utilizar para crear paneles de pared para boiserie, añadiendo elegancia y belleza en cualquier ambiente.*

## Produtos | Products | Productos



Boiserie | Wall Paneling  
Cód. | Code - 28691



Boiserie | Wall Paneling  
Cód. | Code - 28692



Boiserie | Wall Paneling  
Cód. | Code - 28693



Boiserie | Wall Paneling  
Cód. | Code - 28694



### Rápido e prático de aplicar DIY - Faça você mesmo

*Quick and easy to apply - DIY - Do it yourself  
DIY - Hágalo usted mismo - Rápido y práctico de instalar*

### Fita dupla face em todo o verso

*Comes with Double sided tape on back of product  
Incluye cinta doble cara en la parte posterior de lo producto*

### Com nível para ajuste rápido

*Comes with level for perfect and quick setting  
Incluye nivel para un ajuste perfecto y rápido*



Porta: 2,10m x 0,80m  
Based on door size: 2,10m x 0,80m  
Puerta: 2,10m x 0,80m

Utilize Santa Luzia  
Massa Premium  
na cor BRANCA para um  
acabamento perfeito.

Use Santa Luzia **WHITE** premium caulk  
for a perfect finish.  
Utilice Santa Luzia masilla **BLANCA**  
premium para un acabado perfecto.





Produtos | Products | Productos

① Sócalo 204

② 544 RP/BR

③ 543 GN/BR

③

②

①



Inspirada no movimento Art Déco iniciado na França há mais de 90 anos, a coleção traz traços firmes e formatos geométricos para quem gosta de estilo com sobriedade, ordem e simetria.

*This collection brings firm collection and geometric shapes to those who like style with sobriety, order and symmetry.*

*La colección trae trazos firmes y formatos geométricos para quienes gustan de estilo con sobriedad, orden y simetría.*

## Produtos | Products | Productos



**544 RP/BR**  
Skirting Board White | Zócalo Blanco  
Cód. | Code - 27854



**542 RW/BR**  
Trim White | Guardasilla Blanco  
Cód. | Code - 27853



**545 RT/BR**  
Crown White | Cornisa Blanco  
Cód. | Code - 27855



**543 GN/BR**  
Door Case White  
Contramarco Blanco  
Cód. | Code - 27852

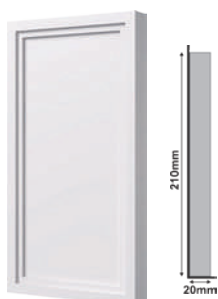

**Sócalo 204 | Plinth Block | Zocalin**  
110 x 210 x 20mm  
Cód. | Code - 27868



**Roseta 203 | Rossete | Roseta**  
100 x 100 x 20mm  
Cód. | Code - 27867

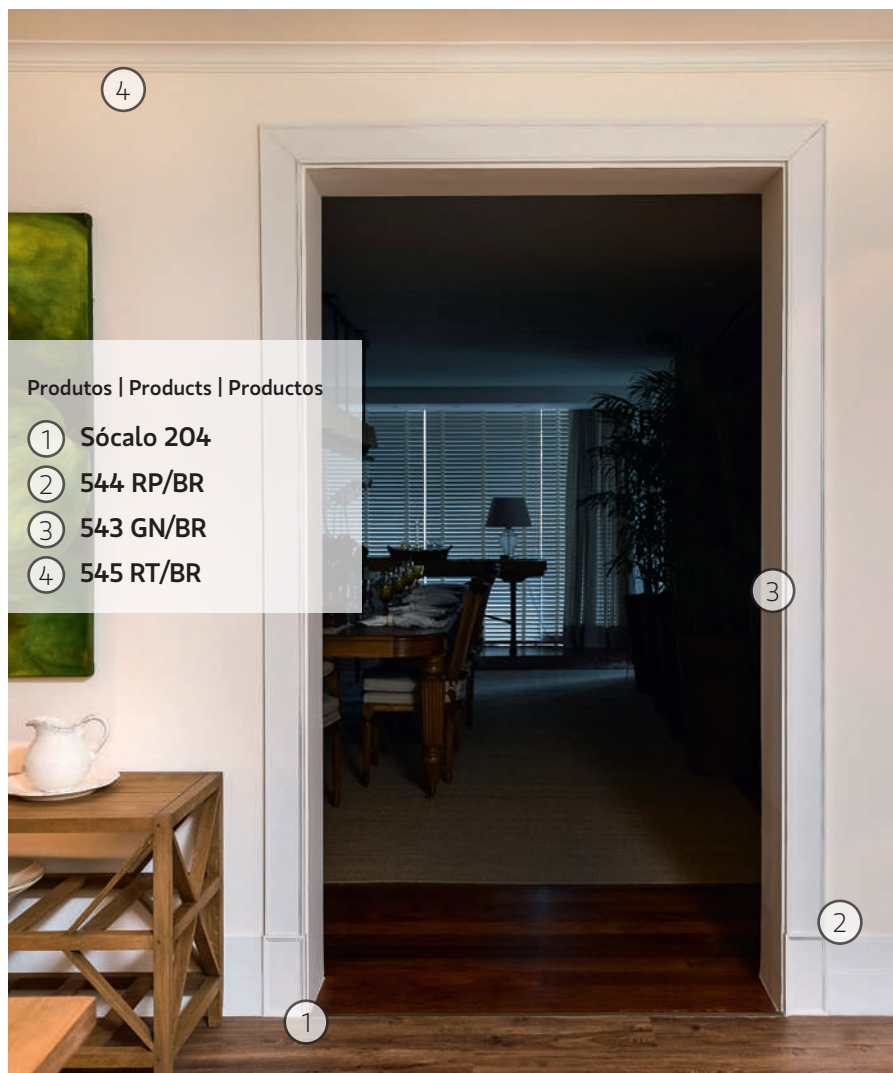

### Produtos | Products | Productos

- ① Sócalo 204
- ② 544 RP/BR
- ③ 543 GN/BR
- ④ 545 RT/BR

Arq. Mariela Klann Fonteyne - Foto: Miro Martins



Utilize Santa Luzia  
Massa Premium  
na cor BRANCA para um  
acabamento perfeito.

Use Santa Luzia WHITE premium caulk  
for a perfect finish.  
Utilice Santa Luzia masilla BLANCA  
premium para un acabado perfecto.





Produto | Product | Producto

① 523 RP/BR

①

Uma composição entre detalhes e desenhos que se diferenciam em um jogo de contrastes e harmonias.

*A composition of details and designs that differ in a game of contrasts and harmonies in which the pieces fit together in unusual ways.*

*Una composición de detalles y diseños que difieren en un juego de contrastes y armonías donde las piezas se acoplan de manera inusual.*

## Rodapés | Skirting Board | Zócalos

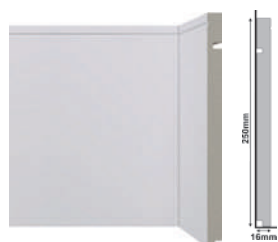

**520 RP/BR**  
Skirting Board White | Zócalo Blanco  
Cód. | Code - 27080



**519 RP/BR**  
Skirting Board White | Zócalo Blanco  
Cód. | Code - 27079



**518 RP/BR**  
Skirting Board White | Zócalo Blanco  
Cód. | Code - 27078



**524 RP/BR**  
Skirting Board White | Zócalo Blanco  
Cód. | Code - 27084



**523 RP/BR**  
Skirting Board White | Zócalo Blanco  
Cód. | Code - 27083



**522 RP/BR**  
Skirting Board White | Zócalo Blanco  
Cód. | Code - 27082

## Guarnições Casings | Contramarcos



**517 GN/BR**  
Door Case White  
Contramarco Blanco  
Cód. | Code - 27077



**521 GN/BR**  
Door Case White  
Contramarco Blanco  
Cód. | Code - 27081

## Sócalos e Rosetas | Plinth Blocks and Rosettes | Zócalins y Rosetas



**Sócalo 196 | Plinth Block | Zócalin**  
110 x 260 x 20mm  
Cód. | Code - 27024



**Sócalo 195 | Plinth Block | Zócalin**  
110 x 210 x 20mm  
Cód. | Code - 27023



**Sócalo 194 | Plinth Block | Zócalin**  
110 x 160 x 20mm  
Cód. | Code - 27022



**Roseta 193**  
Rosette | Roseta  
100 x 100 x 20mm  
Cód. | Code - 27021

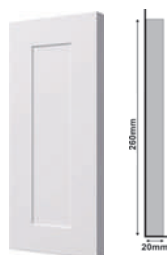

**Sócalo 200 | Plinth Block | Zócalin**  
110 x 260 x 20mm  
Cód. | Code - 27028



**Sócalo 199 | Plinth Block | Zócalin**  
110 x 210 x 20mm  
Cód. | Code - 27027



**Sócalo 198 | Plinth Block | Zócalin**  
110 x 160 x 20mm  
Cód. | Code - 27026



**Roseta 197**  
Rosette | Roseta  
100 x 100 x 20mm  
Cód. | Code - 27025



Utilize Santa Luzia  
Massa Premium  
na cor BRANCA para um  
acabamento perfeito.

Use Santa Luzia WHITE premium caulk  
for a perfect finish.  
Utilice Santa Luzia masilla BLANCA  
premium para un acabado perfecto.



Produtos | Products | Productos

- ① 518 RP/Cinza Glacial
- ② 517 GN/Cinza Glacial
- ③ 194 Sócalo/Cinza Glacial

Duas cores exclusivas formam a Coleção Inova Uber, permitindo maior customização, elegância e aconchego a diversos ambientes.

*Two unique colors create the Inova Collection Uber, allowing greater customization, elegance and warmth to diverse environments.*

*Dos colores exclusivos forman la Colección Inova Uber, lo que permite una mayor personalización, elegancia y comodidad a diversos ambientes.*

## Rodapés | Skirting Boards | Zócalos

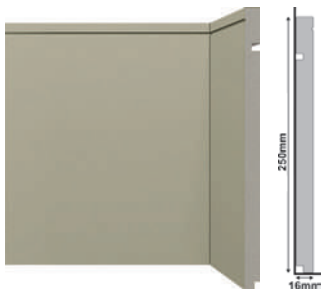

**520 RP/Cinza Glacial**  
Skirting Board Glacial Gray  
Zócalo Gris Glacial  
Cód. | Code - 27532



**519 RP/Cinza Glacial**  
Skirting Board Glacial Gray  
Zócalo Gris Glacial  
Cód. | Code - 27531



**518 RP/Cinza Glacial**  
Skirting Board Glacial Gray  
Zócalo Gris Glacial  
Cód. | Code - 27530

## Sócalos e Rosetas | Plinth Blocks and Rosettes | Zócalins y Rosetas

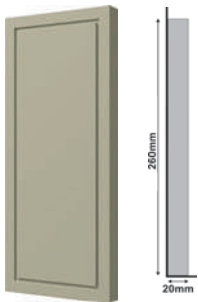

**Sócalo 196 Cinza Glacial**  
Plinth Block Glacial Gray  
Zócalin Gris Glacial  
110 x 260 x 20mm  
Cód. | Code - 27536

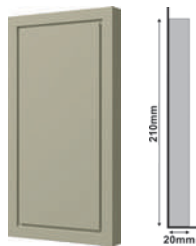

**Sócalo 195 Cinza Glacial**  
Plinth Block Glacial Gray  
Zócalin Gris Glacial  
110 x 210 x 20mm  
Cód. | Code - 27535

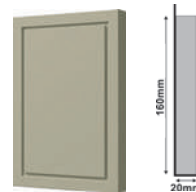

**Sócalo 194 Cinza Glacial**  
Plinth Block Glacial Gray  
Zócalin Gris Glacial  
110 x 160 x 20mm  
Cód. | Code - 27534

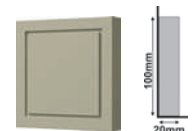

**Roseta 193 Cinza Glacial**  
Rosette Glacial Gray  
Roseta Gris Glacial  
100 x 100 x 20mm  
Cód. | Code - 27533

## Guarniões | Casings | Contramarcos

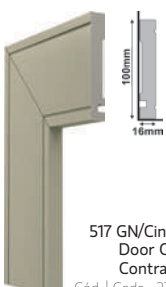

**517 GN/Cinza Glacial**  
Door Case Glacial Gray  
Contramarco Gris Glacial  
Cód. | Code - 27529

Utilize Santa Luzia Massa Premium nas cores do produto.

Use Santa Luzia premium caulk in product colors.  
Utilice Santa Luzia masilla premium en los colores del producto.



## Rodapés | Skirting Boards | Zócalos

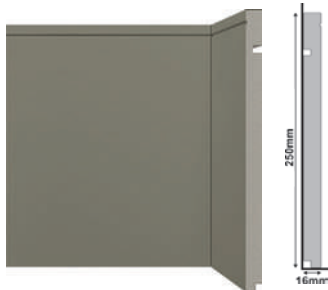

520 RP/Cinza Titanium  
Skirting Board Titanium Gray  
Zócalo Gris Titano  
Cód. | Code - 27524



519 RP/Cinza Titanium  
Skirting Board Titanium Gray  
Zócalo Gris Titano  
Cód. | Code - 27523



518 RP/Cinza Titanium  
Skirting Board Titanium Gray  
Zócalo Gris Titano  
Cód. | Code - 27522

## Sócalos e Rosetas | Plinth Blocks and Rosettes | Zócalins y Rosetas

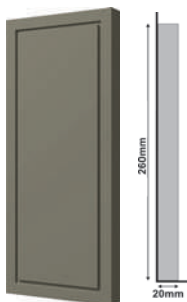

Sócalo 196 Cinza Titanium  
Plinth Block Titanium Gray  
Zócalin Gris Titano  
110 x 260 x 20mm  
Cód. | Code - 27528

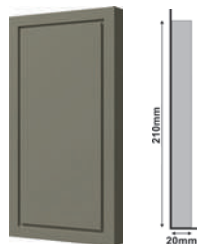

Sócalo 195 Cinza Titanium  
Plinth Block Titanium Gray  
Zócalin Gris Titano  
110 x 210 x 20mm  
Cód. | Code - 27527



Sócalo 194 Cinza Titanium  
Plinth Block Titanium Gray  
Zócalin Gris Titano  
110 x 160 x 20mm  
Cód. | Code - 27526

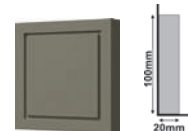

Roseta 193 Cinza Titanium  
Rosette Titanium Gray  
Roseta Gris Titano  
100 x 100 x 20mm  
Cód. | Code - 27525

## Guarniões | Casings | Contramarcos

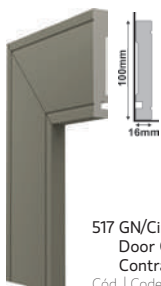

517 GN/Cinza Titanium  
Door Case Titanium Gray  
Contramarco Gris Titano  
Cód. | Code - 27521



Utilize Santa Luzia Massa Premium nas cores do produto.

Use Santa Luzia premium caulk in product colors.  
Utilice Santa Luzia masilla premium en los colores del producto.





Produtos | Products | Productos

① 520 RP/Cinza Titanium

DANIELA COLNAGHI

①



1

Produto | Product | Producto

① 496 RP/Cinza Titanium

# Coleção **POP DECOR**



Pop Decor Collection | Colección Pop Decor

Barras de 2,40m | 240 cm bars

Unindo o mix de perfis da Santa Luzia mais procurados nas revendas às nuances do cinza, a Pop Decor é a solução ideal para decorações contemporâneas de paleta neutra, complementando-se suavemente nas tonalidades Titanium e Glacial a móveis, pinturas e outros acabamentos. A linha reúne, entre modelos de superfície lisa e frisada, seis opções de rodapé, quatro de guarnição, três sócalos e duas rosetas.

*Combining the mix of Santa Luzia's most sought out profiles at retailers with the nuances of gray, Pop Decor is the ideal solution for contemporary neutral palette decoration. The line brings together, smooth and beaded surface models, six baseboard options, four casings, three plinth blocks and two rosettes.*

*Uniendo la mezcla más codiciada de los perfiles de Santa Luzia en las reventas con los matices del gris, Pop Decor es la solución ideal para decoraciones de paletas neutras contemporáneas, complementándose suavemente en tonos titanio y glacial con muebles, pinturas y otros Acabados. La línea reúne, entre modelos de superficie lisa y con cuentas, seis opciones de zócalos, cuatro de guarniciones, tres socelines y dos rosetas.*

## Guarnições | Casings | Contramarcos

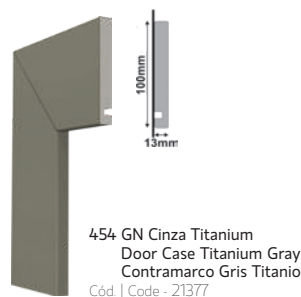
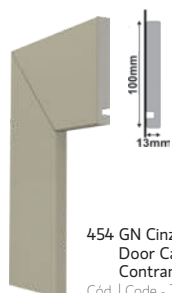

**A Coleção Pop Decor oferece Terminais de Acabamento sob Encomenda. Veja todos os modelos em acessórios (página 62).**

The Pop Decor Collection offers customized Finishing Corners. See all in accessories (page 62).

La colección Pop Decor ofrece Guardias de Topo hechos a pedido. Vea todos en accesorios (p. 62).

**Rodapés | Skirting Boards | Zócalos**

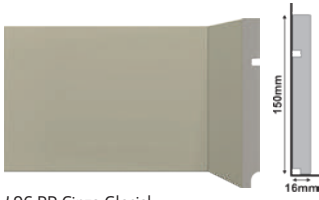

**496 RP Cinza Glacial**  
Skirting Board Glacial Gray  
Zócalo Gris Glacial

Cód. | Code - 21380



**454 RP Cinza Glacial**  
Skirting Board Glacial Gray  
Zócalo Gris Glacial

Cód. | Code - 21375



**451 RP Cinza Glacial**  
Skirting Board Glacial Gray  
Zócalo Gris Glacial

Cód. | Code - 21367

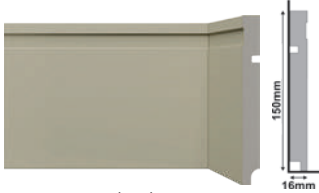

**480 RP Cinza Glacial**  
Skirting Board Glacial Gray  
Zócalo Gris Glacial

Cód. | Code - 29869

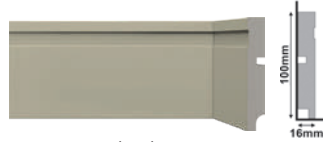

**457 RP Cinza Glacial**  
Skirting Board Glacial Gray  
Zócalo Gris Glacial

Cód. | Code - 29867



**456 RP Cinza Glacial**  
Skirting Board Glacial Gray  
Zócalo Gris Glacial

Cód. | Code - 21371

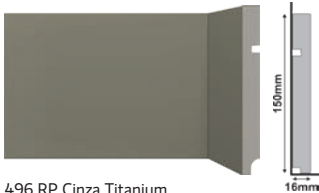

**496 RP Cinza Titanium**  
Skirting Board Titanium Gray  
Zócalo Gris Titanio

Cód. | Code - 21381



**454 RP Cinza Titanium**  
Skirting Board Titanium Gray  
Zócalo Gris Titanio

Cód. | Code - 28730

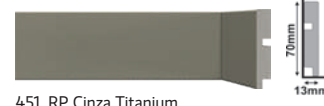

**451 RP Cinza Titanium**  
Skirting Board Titanium Gray  
Zócalo Gris Titanio

Cód. | Code - 21369

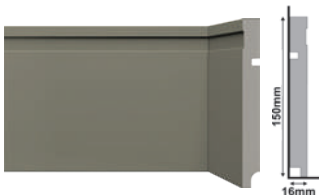

**480 RP Cinza Titanium**  
Skirting Board Titanium Gray  
Zócalo Gris Titanio

Cód. | Code - 29870



**457 RP Cinza Titanium**  
Skirting Board Titanium Gray  
Zócalo Gris Titanio

Cód. | Code - 29868



**456 RP Cinza Titanium**  
Skirting Board Titanium Gray  
Zócalo Gris Titanio

Cód. | Code - 21373

**Sócalos e Rosetas | Plinth Blocks and Rosettes | Zócalins y Rosetas**

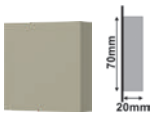

**Roseta 175 Cinza Glacial**  
Rosette Glacial Gray  
Roseta Gris Glacial

70 x 70 x 20mm

Cód. | Code - 21382

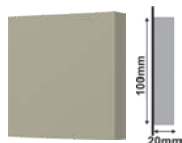

**Roseta 176 Cinza Glacial**  
Rosette Glacial Gray  
Roseta Gris Glacial

100 x 100 x 20mm

Cód. | Code - 21384

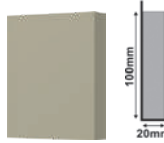

**Sócalo 177 Cinza Glacial**  
PLinth Block Glacial Gray  
Zócalin Gris Glacial

80 x 100 x 20mm

Cód. | Code - 29276

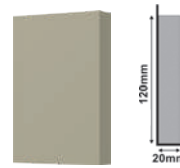

**Sócalo 178 Cinza Glacial**  
PLinth Block Glacial Gray  
Zócalin Gris Glacial

80 x 120 x 20mm

Cód. | Code - 21387

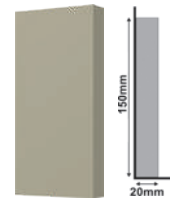

**Sócalo 183 Cinza Glacial**  
PLinth Block Glacial Gray  
Zócalin Gris Glacial

70 x 150 x 20mm

Cód. | Code - 21389

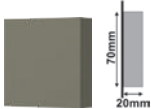

**Roseta 175 Cinza Titanium**  
Rosette Titanium Gray  
Roseta Gris Titanio

70 x 70 x 20mm

Cód. | Code - 21383

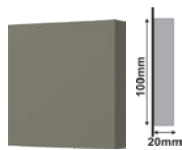

**Roseta 176 Cinza Titanium**  
Rosette Titanium Gray  
Roseta Gris Titanio

100 x 100 x 20mm

Cód. | Code - 21385

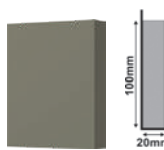

**Sócalo 177 Cinza Titanium**  
PLinth Block Titanium Gray  
Zócalin Gris Titanio

80 x 100 x 20mm

Cód. | Code - 21386

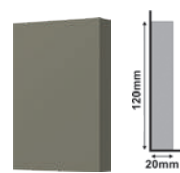

**Sócalo 178 Cinza Titanium**  
PLinth Block Titanium Gray  
Zócalin Gris Titanio

80 x 120 x 20mm

Cód. | Code - 21388

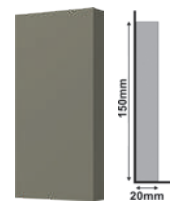

**Sócalo 183 Cinza Titanium**  
PLinth Block Titanium Gray  
Zócalin Gris Titanio

70 x 150 x 20mm

Cód. | Code - 21390



Produto | Product | Producto

① 3505 RP/Black



①



# Coleção Black

Black Collection | Colección Black

Barros de 2,40m | 240 cm bars

HISTÓRIA, inovação e responsabilidade socioambiental.

*HISTORY, innovation and socio-environmental responsibility.*

*HISTORIA, innovación y responsabilidad social y ambiental.*

## Rodapés | Skirting Boards | Zócalos



3505 RP/Black  
Skirting Board Black | Zócalo Negro  
Cód. | Code - 27086



3461 RP/Black  
Skirting Board Black | Zócalo Negro  
Cód. | Code - 26450



3480 RP/Black  
Skirting Board Black | Zócalo Negro  
Cód. | Code - 26449



3496 RP/Black  
Skirting Board Black | Zócalo Negro  
Cód. | Code - 29293



NOVO  
3451 RP/Black  
Skirting Board Black | Zócalo Negro  
Cód. | Code - 21365



3457 RP/Black  
Skirting Board Black | Zócalo Negro  
Cód. | Code - 26445



3547 RP/Black  
Skirting Board Black | Zócalo Negro  
Cód. | Code - 29294



3444 RP/Black  
Skirting Board Black | Zócalo Negro  
Cód. | Code - 26448



3466 RP/Black  
Skirting Board Black | Zócalo Negro  
Cód. | Code - 27537

## Sócalos e Rosetas | Plinth Blocks and Rosettes | Zócalins y Rosetas



3181 Sócalo Black  
Plinth Block Black | Zócalin Negro  
110 x 220 x 20mm  
Cód. | Code - 27592



3187 Sócalo Black  
Plinth Block Black | Zócalin Negro  
110 x 160 x 20mm  
Cód. | Code - 27593



3176 Roseta Black  
Rosette Black | Roseta Negro  
100 x 100 x 20mm  
Cód. | Code - 27538

## Guarnições | Door Casings | Contramarcos



3457 GN/Black  
Door Case Black  
Contramarco Negro  
Cód. | Code - 26446



3547 GN/Black  
Door Case Black  
Contramarco Negro  
Cód. | Code - 29295



3444 GN/Black  
Door Case Black  
Contramarco Negro  
Cód. | Code - 26447

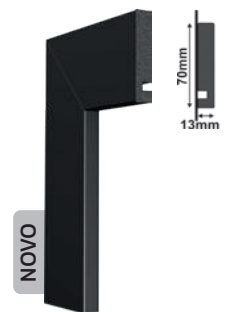

NOVO  
3451 GN/Black  
Door Case Black  
Contramarco Negro  
Cód. | Code - 21366

## Rodameio | Chail Rail | Guardasilla



3466 RM/Black  
Trim Black | Guardasilla Negro  
Cód. | Code - 28663



3448 RM/Black  
Trim Black | Guardasilla Negro  
Cód. | Code - 28686

Utilize Santa Luzia  
Massa Premium Preta

Use Santa Luzia in Black  
premium caulk  
Utilice Santa Luzia masilla  
premium negro.





Produto | Product | Producto

① 3454 GN/Ouro + Filete Ouro

①



Um toque inovador que produz efeitos de pura sofisticação de prata, ouro e cobre para o contorno de ambientes mais ousados.

*An innovative touch that produces effects of pure sophistication of silver, gold and copper for the outline of bolder environments.*

*Un toque innovador que produce efectos de sofisticación de plata, oro y cobre para el entorno de ambientes más osados.*

## Rodapés | Skirting Boards | Zócalos



3454 Rodapé Cobre  
Skirting Board Cooper | Zócalo Cobre  
Cód. | Code - 26680



3454 Rodapé Prata  
Skirting Board Silver | Zócalo Plata  
Cód. | Code - 26684



3454 Rodapé Ouro  
Skirting Board Gold | Zócalo Oro  
Cód. | Code - 26682

## Guarnições | Door Casings | Contramarcos



3454 Guarnição Cobre  
Door Case Cooper  
Contramarco Cobre  
Cód. | Code - 26681



3454 Guarnição Prata  
Door Case Silver  
Contramarco Plata  
Cód. | Code - 26685



3454 Guarnição Ouro  
Door Case Gold  
Contramarco Oro  
Cód. | Code - 26683



Utilize Santa Luzia Massa Premium nas cores COBRE, PRATA ou OURO para um acabamento perfeito.

Use Santa Luzia Massa in Cooper, Silver or Gold Premium caulk for a perfect finish.

Utilice Santa Luzia masilla premium en los colores Cobre, Plata o Oro para un acabado perfecto.

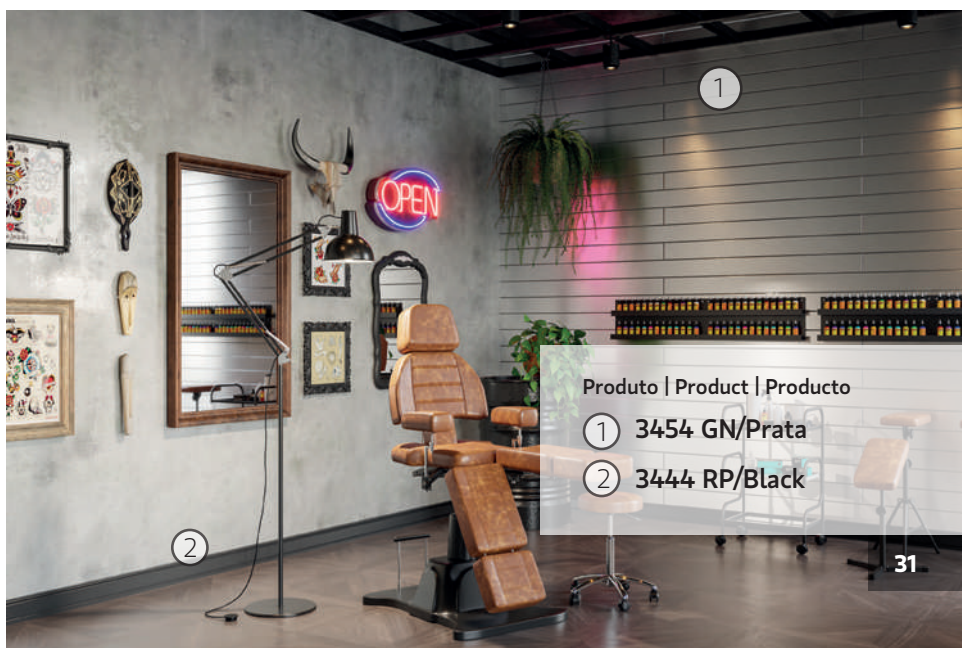

Produto | Product | Producto

① 3454 GN/Prata

② 3444 RP/Black



1

2

Produto | Product | Producto

① 3496 RP/OXI Ouro Rose

② 496 RP/Cinza Titanium

Com a Coleção OXI, a Santa Luzia introduz perfis de acabamentos metálicos com efeito desgastado pelo tempo, seguindo tendência de pisos e revestimentos cerâmicos. A coleção é composta de rodapés de 15 cm de altura e guarnições de 10 cm.

*With the OXI collection, Santa Luzia introduces profiles of metallic finishes with a time-worn effect, following a tendency of floors and ceramic tiles. The collection is composed of 6" high baseboards and 4" casings.*

*Con la colección OXI, Santa Luzia introduce perfiles de acabados metálicos con un efecto desgastado por el tiempo, siguiendo una tendencia de pisos y baldosas cerámicas. La colección está compuesta de zócalos de 15 cm de alto y contramarcos de 10 cm.*

## Rodapés | Skirting Boards | Zócalos



3496 RP OXI Preto  
Skirting Board OXI Black | Zócalo OXI Negro  
Cód. | Code - 28585



3496 RP OXI Prata  
Skirting Board OXI Silver | Zócalo OXI Plata  
Cód. | Code - 28586



3496 RP OXI Ouro  
Skirting Board OXI Gold | Zócalo OXI Oro  
Cód. | Code - 28587



3496 RP OXI Ouro Rose  
Skirting Board OXI Rose Gold | Zócalo OXI Oro Rosa  
Cód. | Code - 28588



Utilize Santa Luzia Massa Premium nas cores PRETA, COBRE, PRATA ou OURO para um acabamento perfeito.  
Use Santa Luzia premium caulk in BLACK, COPPER, SILVER or GOLD for a perfect finish.  
Utilice Santa Luzia masilla premium en NEGRO, COBRE PLATA o ORO para un acabado perfecto.

## Guarnições | Door Casings | Contramarcos

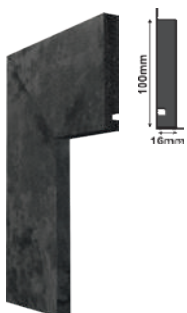

3547 GN OXI Preto  
Door Case OXI Black  
Contramarco OXI Negro  
Cód. | Code - 28589

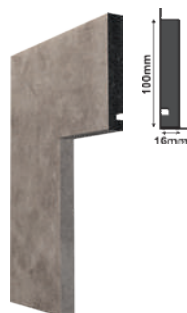

3547 GN OXI Prata  
Door Case OXI Silver  
Contramarco OXI Plata  
Cód. | Code - 28590

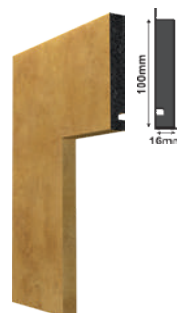

3547 GN OXI Ouro  
Door Case OXI Gold  
Contramarco OXI Oro  
Cód. | Code - 28591



3547 GN OXI Ouro Rose  
Door Case OXI Rose Gold  
Contramarco OXI Oro Rosa  
Cód. | Code - 28592



Produto | Product | Producto

① 3454 GN/Maple

② 3454 GN/Cumaru



Uma coleção composta de diferentes cores e texturas inspirados em madeiras nobres.

*A collection composed of different colors and textures inspired by noble woods*

*Una colección compuesta de diferentes colores y texturas inspirados en maderas nobles.*

## Rodapés | Skirting Boards | Zócalos



**3454 RP Ébano**  
Skirting Board Ebony | Zócalo Ebano  
Cód. | Code - 26688



**3454 RP Ipê Escuro**  
Skirting Board Dark Ipe | Zócalo Ipe Oscuro  
Cód. | Code - 26690



**3454 RP Cumaru**  
Skirting Board Base Cumaru | Zócalo Cumaru  
Cód. | Code - 29287



**3454 RP Maple**  
Skirting Board Maple | Zócalo Arce  
Cód. | Code - 29289



**3454 RP Pátina Branca**  
Skirting Board White Patina | Zócalo Patina Blanca  
Cód. | Code - 29288

## Guarniões | Door Casings | Contramarcos



**3454 GN Ébano**  
Door Case Ebony  
Contramarco Ebano  
Cód. | Code - 26689



**3454 GN Ipê Escuro**  
Door Case Dark Ipe  
Contramarco Ipe Oscuro  
Cód. | Code - 26691

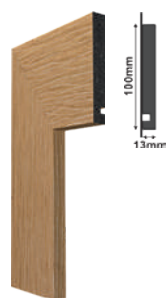

**3454 GN Cumaru**  
Door Case Cumaru  
Contramarco Cumaru  
Cód. | Code - 29290

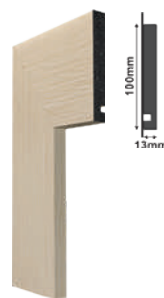

**3454 GN Maple**  
Door Case Maple  
Contramarco Arce  
Cód. | Code - 29292

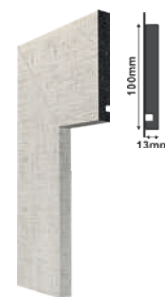

**3454 GN Pátina Branca**  
Door Case White Patina  
Contramarco Patina Blanca  
Cód. | Code - 29291

Utilize Santa Luzia Massa Premium nas cores BRANCA, OURO, CARVALHO PRATA, IPÊ ESCURO ou PRETA para um acabamento perfeito.

Use Santa Luzia premium caulk in WHITE, GOLD, BLACK, DARK IPE or SILVER OAK for a perfect finish.  
Utilice Santa Luzia masilla premium en BLANCO, ARCE, IPE OSCURO, NEGRO o ORO para un acabado perfecto.





Produto | Product | Producto

① 565 RP/Ébano

①



# Coleção Natural

PRODUTO  
**SANTALUZIA**

Wood Collection | Colección Natural

Barras de 2,40m | 240 cm bars

Essa coleção amadeirada foi redesenhada para permitir ajustes perfeitos em qualquer tipo de piso, especialmente os laminados. Como o piso laminado tem contração maior que os demais pisos, a sua base com 18mm garante acabamento impecável.

*This woody collection has been redesigned to allow perfect adjustments to any type of flooring, especially laminates. As the laminate flooring has greater contraction than other type of floors, the your baseboard with 11/16" guarantees impeccable finish.*

*Esta colección leñosa ha sido rediseñada para permitir ajustes perfectos a cualquier tipo de pisos, especialmente laminados. Como el suelo laminado tiene una mayor contracción que los otros pisos, el zócalo con 18mm garantiza un acabado impecable.*

## Rodapés | Skirting Boards | Zócalos



565 RP Ébano  
Skirting Board Ebony | Zócalo Ebano  
Cód. | Code - 28624



565 RP Ipê Escuro  
Skirting Board Dark Ipe | Zócalo Ipe Oscuro  
Cód. | Code - 28625



565 RP Canela  
Skirting Board Cinnamon | Zócalo Canela  
Cód. | Code - 28626



565 RP Cedro  
Skirting Board Cedar | Zócalo Cedro  
Cód. | Code - 28627



565 RP Pau Marfim  
Skirting Board Ivory Wood | Zócalo Madera de Marfil  
Cód. | Code - 28628



565 RP Carvalho Prata  
Skirting Board Silver OAK | Zócalo Carvalho Plata  
Cód. | Code - 28629

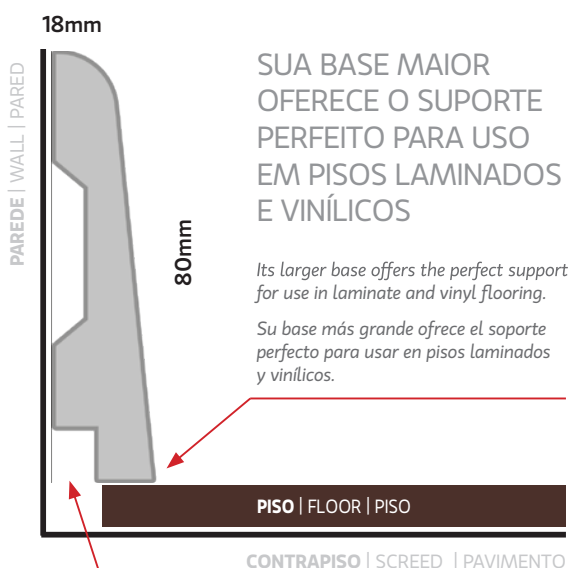

JUNTA DE DILATAÇÃO  
Floor expansion joint  
Junta de dilatación



Para acabamento utilize Massa Premium, Dupla face e Super adesivo Santa Luzia

Use Santa Luzia premium caulk, double sided tape and Santa Luzia Heavy Duty Adhesive for installation and perfect finish. Utilice Santa Luzia masilla premium, cinta doble cara y Super Pegatina Santa Luzia para instalación y acabado perfectos.

# Coleção Natural

PRODUTO  
**SANTALUZIA**

Wall Collection | Colección Natural

Barra de 2,40m | 240 cm bars

## Rodapés | Skirting Boards | Zócalos



446 RP/NA-01  
Skirting Board Natural 01 | Zócalo Natural 01  
Cód. | Code -20108



446 RP/NA-02  
Skirting Board Natural 02 | Zócalo Natural 02  
Cód. | Code -20216



446 RP/NA-03  
Skirting Board Natural 03 | Zócalo Natural 03  
Cód. | Code -20217



446 RP/NA-04  
Skirting Board Natural 04 | Zócalo Natural 04  
Cód. | Code -20218



446 RP/NA-05  
Skirting Board Natural 05 | Zócalo Natural 05  
Cód. | Code -20219



446 RP/NA-06  
Skirting Board Natural 06 | Zócalo Natural 06  
Cód. | Code -20220



446 RP/NA-07  
Skirting Board Natural 07 | Zócalo Natural 07  
Cód. | Code -25557



Para acabamento do NA-01 utilizar massa PRATA, NA-02, NA-03, NA-04 e NA-07 utilizar massa OURO, NA-05 utilizar massa COBRE e NA-06 utilizar massa IPÊ ESCURO.

Para acabado NA01 utilice masila PLATA, NA-02, NA-03, NA-04 e NA-07 utilice masila ORO, NA-05 utilice masila COBRE y NA-06 utilice masila IPÊ OSCURO.

Produto | Product | Producto

① 446 RP/NA-05

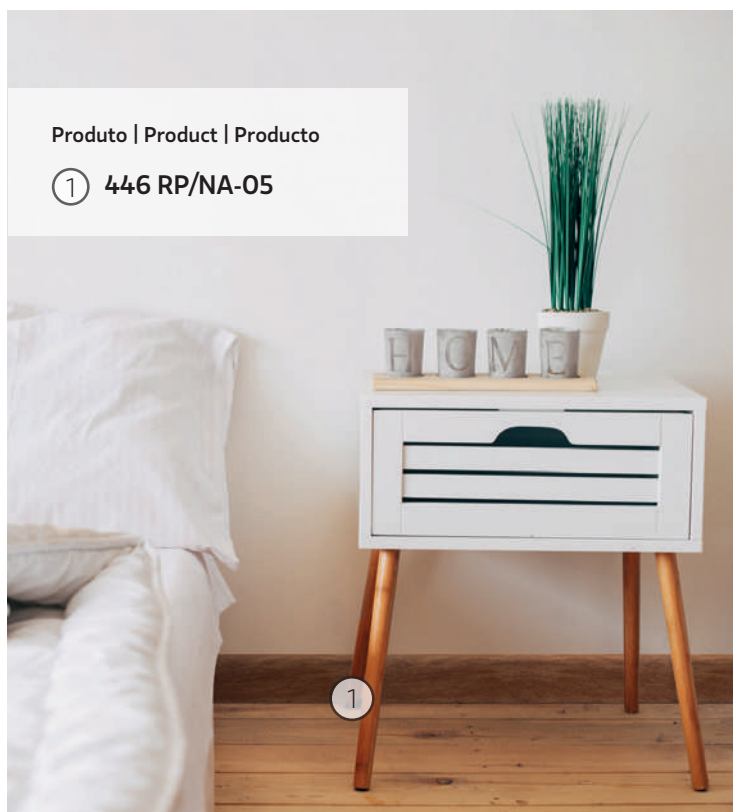



# Os tons amadeirados criam um clima acolhedor e confortável.

*Tones of wood create a cozy and comfortable atmosphere.*

*Los tonos amaderados crean un clima acogedor y comfortable.*

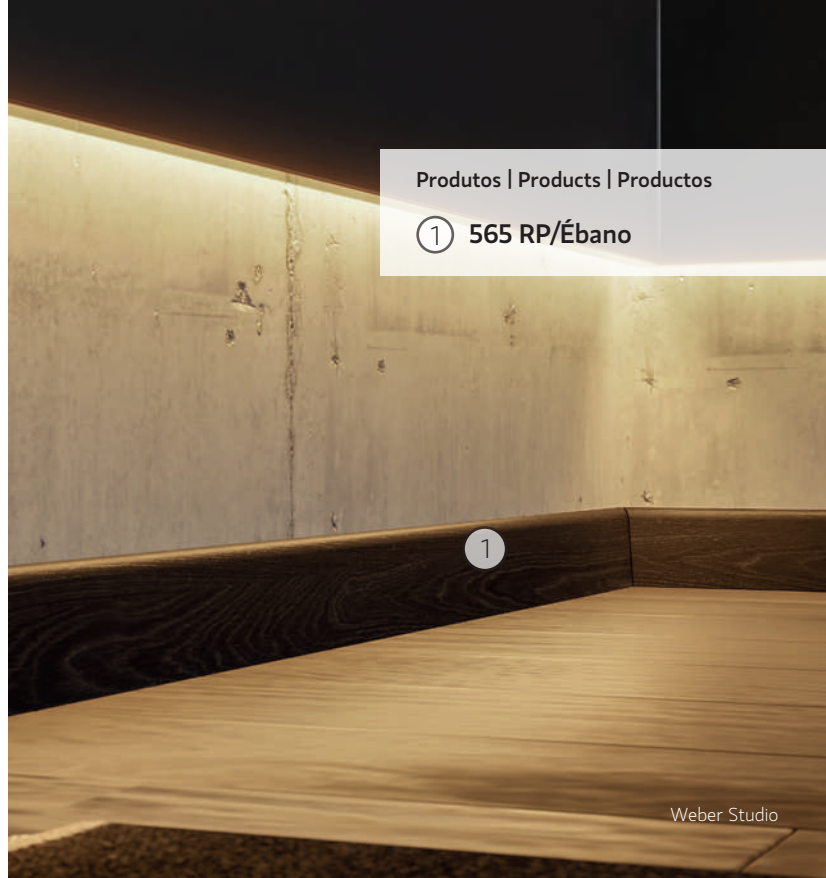

Weber Studio

## Guarnições | Door Casings | Contramarcos



446 GN/NA 01  
Door Case Natural 01  
Contramarco Natural 01  
Cód. | Code - 20221



446 GN/NA 02  
Door Case Natural 02  
Contramarco Natural 02  
Cód. | Code - 20222



446 GN/NA 03  
Door Case Natural 03  
Contramarco Natural 03  
Cód. | Code - 20223



446 GN/NA 04  
Door Case Natural 04  
Contramarco Natural 04  
Cód. | Code - 20224



446 GN/NA 05  
Door Case Natural 05  
Contramarco Natural 05  
Cód. | Code - 20225



446 GN/NA 06  
Door Case Natural 06  
Contramarco Natural 06  
Cód. | Code - 20226



446 GN/NA 07  
Door Case Natural 07  
Contramarco Natural 07  
Cód. | Code - 25745

Produto | Product | Producto

① 548 RP/Reforma

①



# Linha Reforma

Refit Wall Line | Línea Reforma

Barras de 2,40m | 240 cm bars

São três tamanhos que podem ser sobrepostos ao rodapé antigo, com ajuste perfeito, inclusive em pisos laminados. É ideal para reformas, por sua praticidade e facilidade de instalação, que dispensa a retirada do rodapé substituído.

*There are three sizes that can be covered fit over on the existing baseboard, with perfect fit. It is ideal for renovations, for its practicality and ease of installation, which does not require removal of the replaced baseboard.*

*Hay tres tamaños que pueden ser solapados en el zócalo actual, con ajuste perfecto, incluyendo pisos laminados. Es ideal para renovaciones, por su practicidad y facilidad de instalación, que no requiere la remoción del zócalo reemplazado.*

## Rodapés | Wall Baseboards | Zócalos



582 RP/BR Reforma  
Refit Skirting Board White  
Zócalo Blanco Reforma  
Cod.: 29298



583 RP/BR Reforma  
Refit Skirting Board White  
Zócalo Blanco Reforma  
Cod.: 29299



548 RP/BR Reforma  
Refit Skirting Board White  
Zócalo Blanco Reforma  
Cod.: 27856

Sobreposição de até 10 cm de largura  
Overlapping up to 10 cm wide  
Sobreponiéndose hasta de ancho 10 cm

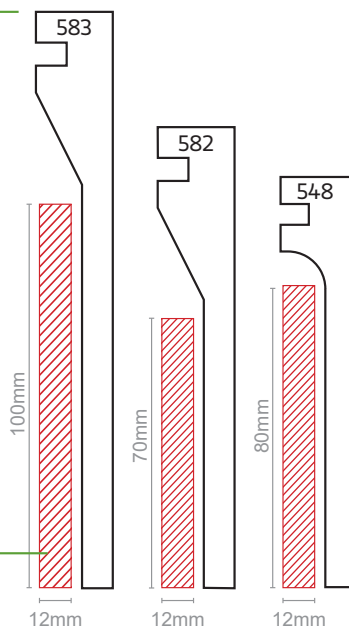

Rodapé antigo  
Current Baseboard  
Zócalo actual

**SOBREPOSIÇÃO  
PERFEITA.  
FÁCIL, RÁPIDA E  
SEM SUJEIRA.**

Perfect Overlap.  
Easy, quick and dirtless.

Superposición perfecta.  
Fácil, rápido y menos suciedad.



Utilize Santa Luzia Massa Premium na cor BRANCA, Fita Dupla Face e Super Adesivo Santa Luzia para instalação e acabamento perfeitos.

Use Santa Luzia WHITE premium caulk, Double Sided Tape and Santa Luzia Heavy Duty Adhesive for installation and perfect finish.

Utilize Santa Luzia masilla BLANCA premium, Cinta Doble Cara y Super Pegatina Santa Luzia para instalación y acabado perfectos.

Produto | Product | Producto

① 496 RP/Melodia do Mar

② 496 RP/Pistache



Weber Studio

coleção

# COLORS

Colors Collection | Colección Colores

## CRIATIVOS, SOFISTICADOS E OUSADOS.

CREATIVE, SOPHISTICATED AND BOLD.  
CREATIVOS, SOFISTICADOS Y AUDACES.

Tons criativos, sofisticados e ousados se reúnem em paleta que remonta os estudos de cor por Le Corbusier.

Uma Paleta Modernista que traz de volta, com nova roupagem, os tons poderosos e vibrantes que dominaram a estética entre os anos de 1930 e 1960.

*Creative, sophisticated and bold tones come together in a palette that dates back to color studies by Le Corbusier. The Modernist Palette brings back, with new manifestation, the powerful and vibrant tones that dominated the aesthetics between the 30's and 60's.*

*Los tonos profundos, sofisticados y audaces se combinan en una paleta que se remonta a los estudios de color de Le Corbusier. La Paleta Modernista trae de vuelta, con una nueva manifestación, los tonos poderosos y vibrantes que dominaron la estética entre los años 30 y 60.*

Barras de 2,40m | 240 cm bars



## Rodapés | Skirting Boards | Zócalos



480 RP/Melodia do Mar  
Melody of the Sea  
Melodía del mar  
Cód. | Code - 28918



480 RP/Eucalipto  
Eucalyptus  
Eucalipto  
Cód. | Code - 28916



480 RP/Pistache  
Pistachio  
Pistacho  
Cód. | Code - 28919



480 RP/Rupestre  
Rock  
Ruprestre  
Cód. | Code - 28917



480 RP/Vermelho Escuro  
Dark Red  
Rojo Oscuro  
Cód. | Code - 28915



480 RP/Tijolo  
Brick  
Ladrillo  
Cód. | Code - 28914

## Guarnições | Door Casings | Contramarcos

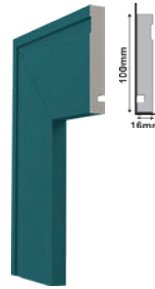

457 GN/Melodia do Mar  
Melody of the Sea  
Melodía del mar  
Cód. | Code - 28912

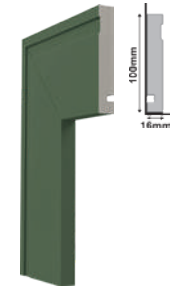

457 GN/Eucalipto  
Eucalyptus  
Eucalipto  
Cód. | Code - 28910

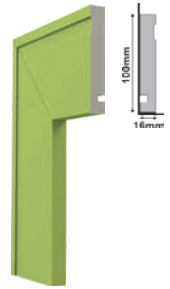

457 GN/Pistache  
Pistachio  
Pistacho  
Cód. | Code - 28913

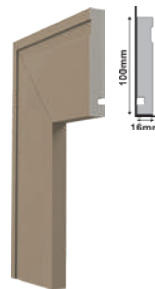

457 GN/Rupestre  
Rock  
Ruprestre  
Cód. | Code - 28911

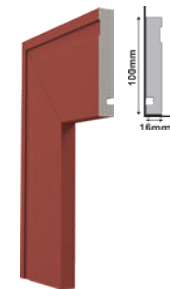

457 GN/Vermelho Escuro  
Dark Red  
Rojo Oscuro  
Cód. | Code - 28909

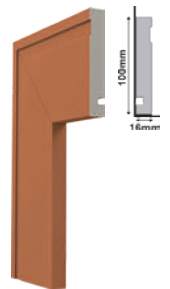

457 GN/Tijolo  
Brick  
Ladrillo  
Cód. | Code - 28908

## Rodapés | Skirting Boards | Zócalos



496 RP/Melodia do Mar  
Melody of the Sea  
Melodía del mar  
Cód. | Code - 29017



496 RP/Eucalipto  
Eucalyptus  
Cód. | Code - 29016

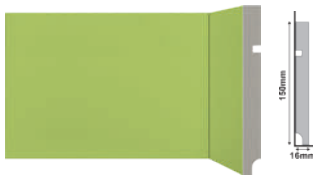

496 RP/Pistache  
Pistachio  
Pistacho  
Cód. | Code - 29020



496 RP/Rupestre  
Rock  
Ruprestre  
Cód. | Code - 29015



496 RP/Vermelho Escuro  
Dark Red  
Rojo Oscuro  
Cód. | Code - 29019



496 RP/Tijolo  
Brick  
Ladrillo  
Cód. | Code - 29018

## Guarnições | Door Casings | Contramarcos

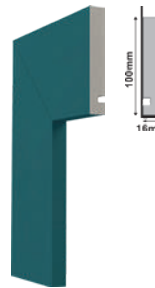

547 GN/Melodia do Mar  
Melody of the Sea  
Melodía del mar  
Cód. | Code - 29023

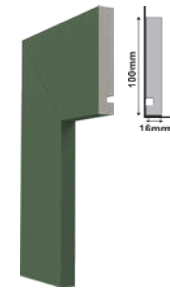

547 GN/Eucalipto  
Eucalyptus  
Eucalipto  
Cód. | Code - 29022

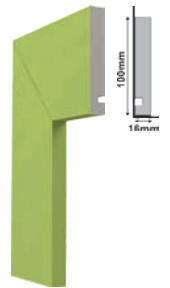

547 GN/Pistache  
Pistachio  
Pistacho  
Cód. | Code - 29026

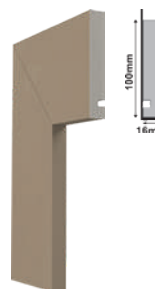

547 GN/Rupestre  
Rock  
Ruprestre  
Cód. | Code - 29021

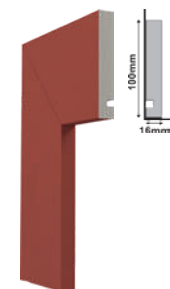

547 GN/Vermelho Escuro  
Dark Red  
Rojo Oscuro  
Cód. | Code - 29025

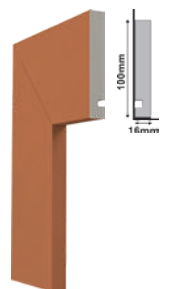

547 GN/Tijolo  
Brick  
Ladrillo  
Cód. | Code - 29024



Produto | Product | Producto

① Ripa + Filete Branco  
(Personalizado)

Coleção  
**MULTI  
LINHA**

Multiline Collection | Colección Multilinea

Barras de 2,80m | 280 cm bars

Multilinha é uma coleção formada por ripas em formato de peças estreitas e alongadas. Versáteis, permitem composições criativas em diferentes superfícies como paredes e móveis, podendo ser aplicadas tanto na vertical como na horizontal.

*Multiline is a collection formed by ribs in the shape of narrow and elongated pieces. Versatile, they allow creative compositions on different surfaces such as walls & furniture and can be applied both vertically and horizontally.*

*Multilinea es una colección formada por listones en forma de piezas estrechas y alargadas. Versátil, permite composiciones creativas en diferentes superficies como paredes y muebles, y se puede aplicar tanto vertical como horizontalmente.*



## Ripas e Filetes

Pro Slatted Wall  
Listones y Filetes



As Ripas de Poliestireno Santa Luzia são produtos versáteis que podem ser usados separadamente ou em conjunto com os Filetes de Poliestireno, permitindo composições de painéis ripados criativos e modernos com lindos efeitos de profundidade e sobreposição.

*Santa Luzia's Polystyrene Pro Slatted Wall are versatile products that can be used separately or in conjunction with Polystyrene Pro Slatted Wall, allowing compositions of creative and modern ripped panels with beautiful effects of depth and overlap.*

*Los listones de poliestireno Santa Luzia son productos versátiles que se pueden utilizar por separado o en combinación con filetes de poliestireno, permitiendo composiciones de paneles alistonados, creativos y modernos, con hermosos efectos de profundidad y superposición.*

### Ripas | Pro Slatted Wall | Listones



Ripa 466 Preto  
Pro Slatted Wall 466 Black  
Listón 466 Negro  
Cód. | Code - 29881



Ripa 466 Branco  
Pro Slatted Wall 466 White  
Listón 466 Blanco  
Cód. | Code - 29880



Ripa 466 Cumaru  
Pro Slatted Wall 466 Cumaru  
Listón 466 Cumaru  
Cód. | Code - 29873



Ripa 466 Curupixá  
Pro Slatted Wall 466 Curupixá  
Listón 466 Curupixá  
Cód. | Code - 29875



Ripa 466 Ipê Escuro  
Pro Slatted Wall 466 Dark Ipe  
Listón 466 Ipe Oscuro  
Cód. | Code - 29874



Ripa 466 Ébano  
Pro Slatted Wall 466 Ebony  
Listón 466 Ebano  
Cód. | Code - 29876



Ripa 466 Prata  
Pro Slatted Wall 466 Silver  
Listón 466 Plata  
Cód. | Code - 29860



Ripa 466 Ouro  
Pro Slatted Wall 466 Gold  
Listón 466 Oro  
Cód. | Code - 29882



Ripa 466 Cobre  
Pro Slatted Wall 466 Cooper  
Listón 466 Cobre  
Cód. | Code - 29883



Ripa 466 Oxi Prata  
Pro Slatted Wall 466 Oxi Silver  
Listón 466 Oxi Plata  
Cód. | Code - 29879



Ripa 466 Oxi Ouro Rosê  
Pro Slatted Wall 466  
Oxi Rose Gold  
Listón 466 Oxi Oro Rosa  
Cód. | Code - 29877



Ripa 466 Oxi Ouro  
Pro Slatted Wall 466 Oxi Gold  
Listón 466 Oxi Oro  
Cód. | Code - 29878

### Filetes | Pro Slatted Wall | Filetes



Filete Preto  
Pro Slatted Wall Black  
Filete Negro  
Cód. | Code - 29863



Filete Branco  
Pro Slatted Wall White  
Filete Blanco  
Cód. | Code - 29862



Filete Cumaru  
Pro Slatted Wall Cumaru  
Filete Cumaru  
Cód. | Code - 29855



Filete Curupixá  
Pro Slatted Wall Curupixá  
Filete Curupixá  
Cód. | Code - 29857



Filete Ipê Escuro  
Pro Slatted Wall Dark Ipe  
Filete Ipe Oscuro  
Cód. | Code - 29856



Filete Ébano  
Pro Slatted Wall Ebony  
Filete Ebano  
Cód. | Code - 29858



Filete Prata  
Pro Slatted Wall Silver  
Filete Plata  
Cód. | Code - 29866



Filete Ouro  
Pro Slatted Wall Gold  
Filete Oro  
Cód. | Code - 29864



Filete Cobre  
Pro Slatted Wall Cooper  
Filete Cobre  
Cód. | Code - 29865



Filete Oxi Prata  
Pro Slatted Wall Oxi Silver  
Filete Oxi Plata  
Cód. | Code - 29861



Filete Oxi Ouro Rosê  
Pro Slatted Wall  
Oxi Rose Gold  
Filete Oxi Oro Rosa  
Cód. | Code - 29859



Filete Oxi Ouro  
Pro Slatted Wall Oxi Gold  
Filete Oxi Oro  
Cód. | Code - 29860

### Tamanhos | Sizes | Tamaños:

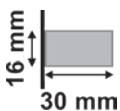

Ripas  
Pro Slatted Wall  
Listones

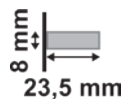

Filetes  
Pro Slatted Wall  
Filetes

### PARA MELHORES EFEITOS DE PROFUNDIDADE E SOBREPOSIÇÃO, INDICAMOS A MONTAGEM INTERCALANDO UMA RIPA MAIS UM FILETE.

*For better depth and overlapping effects, we recommend the assembly of both the Pro Slatted Wall.*

*Para mejores efectos de profundidad y superposición, indicamos el ensamblado intercalando un listón mas un filete.*

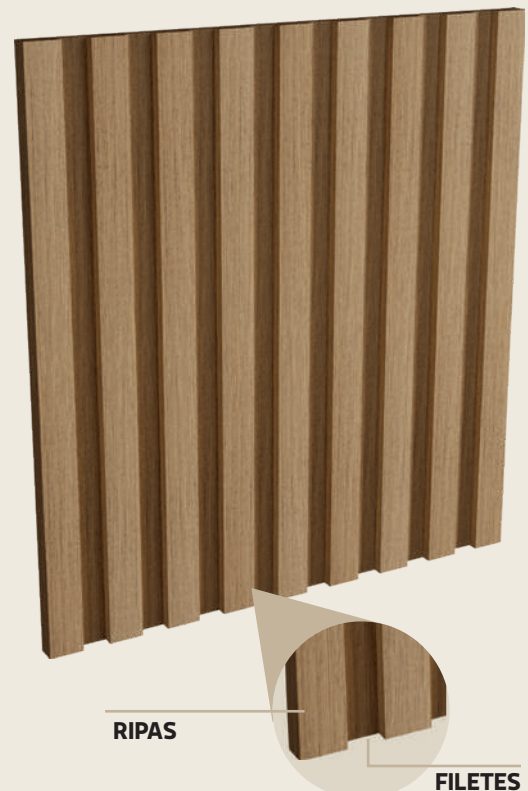

## Ripados de Encaixe

DIY Slatted Boards  
Listones de Encaje



O Ripado de Encaixe é a união entre as Ripas e Filetes de Poliestireno em uma única peça. São disponibilizados em dois tamanhos com 55 e 75 mm de largura. O encaixe é preciso, oferecendo instalação mais rápida, fácil e acabamento impecável.

*The DIY Slatted Wall is the union between the Polystyrene Battens in a single piece. They are available in two sizes, 55 and 75 mm wide. The fit is precise, offering quicker and easier installation and impeccable finishing.*

*El panel alistonado es la unión entre los Listones y los filetes de Poliestireno en una sola pieza. Están disponibles en dos tamaños de 55 y 75 mm de ancho. El ajuste es preciso, ofreciendo una instalación más rápida y fácil y un acabado impecable.*

### Produtos | Products | Productos

55 mm x 16 mm x 2,80 m



Ripado 55 Preto  
DIY Slatted Wall 55 Black  
Listón 55 Negro  
Cód. | Code - 21352



Ripado 55 Branco  
DIY Slatted Wall 55 White  
Listón 55 Blanco  
Cód. | Code - 21353



Ripado 55 Cumaru  
DIY Slatted Wall 55 Cumaru  
Listón 55 Cumaru  
Cód. | Code - 21354



Ripado 55 Curupixá  
DIY Slatted Wall 55 Curupixa  
Listón 55 Curupixa  
Cód. | Code - 21355



Ripado 55 Ipê Escuro  
DIY Slatted Wall 55 Dark Ipe  
Listón 55 Ipe Oscuro  
Cód. | Code - 21356



Ripado 55 Ébano  
DIY Slatted Wall 55 Ebony  
Listón 55 Ebano  
Cód. | Code - 21357

75 mm x 16 mm x 2,80 m



Ripado 75 Preto  
DIY Slatted Wall 75 Black  
Listón 75 Negro  
Cód. | Code - 21358



Ripado 75 Branco  
DIY Slatted Wall 75 White  
Listón 75 Blanco  
Cód. | Code - 21359



Ripado 75 Cumaru  
DIY Slatted Wall 75 Cumaru  
Listón 75 Cumaru  
Cód. | Code - 21360



Ripado 75 Curupixá  
DIY Slatted Wall 75 Curupixa  
Listón 75 Curupixa  
Cód. | Code - 21361



Ripado 75 Ipê Escuro  
DIY Slatted Wall 75 Dark Ipe  
Listón 75 Ipe Oscuro  
Cód. | Code - 21362



Ripado 75 Ébano  
DIY Slatted Wall 75 Ebony  
Listón 75 Ebano  
Cód. | Code - 21363



**ENCAIXE PRECISO  
ACABAMENTO IMPECÁVEL**

*Precise fit, impeccable finish*

*Ajuste preciso, acabado impecable*

Tamanhos | Sizes | Tamaños:

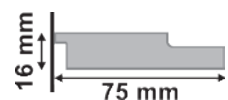
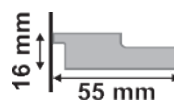



## Ripas Pinus

Yellow Pine Slatted Wall  
Listones de Pino



A madeira natural garante um ótimo resultado para um painel ripado, onde normalmente se utiliza ripas em tons mais claros para não 'carregar' os ambientes. Com a Coleção Multilinha, a Santa Luzia oferece ripas produzidas com pinus de reflorestamento. Para garantir um aspecto ainda mais natural, a empresa preserva os nós da madeira.

*The natural wood guarantees a great result for a ripped panel, where Slatted Wall in lighter tones are normally used to not "weigh down" environments. To ensure an even more natural look, the company preserves the wood knots.*

*La madera natural garantiza un gran resultado para un panel alistonado, donde los listones se utilizan generalmente en tonos más claros para no 'cargar' los ambientes. Con la Colección Multilínea Santa Luzia ofrece listones producidos con pinos de reforestación tratada. Para garantizar un aspecto aún más natural, la empresa conserva los nudos de la madera.*

## O CHARME DA MADEIRA NATURAL

THE CHARM OF  
NATURAL WOOD

EL ENCANTO DE LA  
MADERA NATURAL

### Produtos | Products | Productos



Ripa Pinus 50x28  
Yellow Pine Slatted Wall 50x28  
Listón de Pino 50x28  
Cód. | Code - 29803

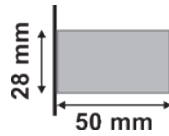

Ripa Pinus 28x28  
Yellow Pine Slatted Wall 28x28  
Listón de Pino 28x28  
Cód. | Code - 29804

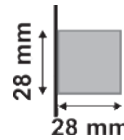

Ripa Pinus 14x28  
Yellow Pine Slatted Wall 14x28  
Listón de Pino 14x28  
Cód. | Code - 29802

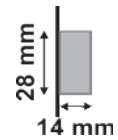

Weber Studio

Produto | Product | Producto

① Ripa Pinus 50x28

①



Produto | Product | Producto

① Ecodeck Imbuia

①

Weber Studio



WPC Deck Line | Línea Ecodeck

A coleção de ecodecks foi revitalizada, passando a contemplar os formatos Mini e Maxi. O espaçamento entre as placas foi reduzido a 3 mm, reduzindo possíveis danos aos calçados de salto fino. Fabricados em WPS, os produtos estão disponíveis na marcante cor imbuia para aplicações em áreas externas e internas, como em área de piscina.

*The WPC Deck collection was revitalized, now including Mini and Maxi formats. The spacing between the plates was reduced to 3 mm, reducing possible damage to thin heeled shoes. Manufactured in WPS, the products are available in a striking imbuia color for applications in outdoor and indoor areas, such as in the pool area.*

*La colección de Ecodeck se revitalizó, contemplando ahora los formatos Mini y Maxi. El espacio entre las placas se redujo a 3 mm, reduciendo el posible daño a los calzados de tacón delgado. Fabricados en WPS, los productos están disponibles en llamativo color Imbuia para aplicaciones en áreas externas e internas, como puede ser el área de la piscina.*

Produtos | Products | Productos

## MAXIDECK

Barra | Bar | Barra 240 x 12,5 x 2,4 cm



Maxideck Imbuia | Brazilian Walnut | Imbuia  
Cód. | Code - 21349

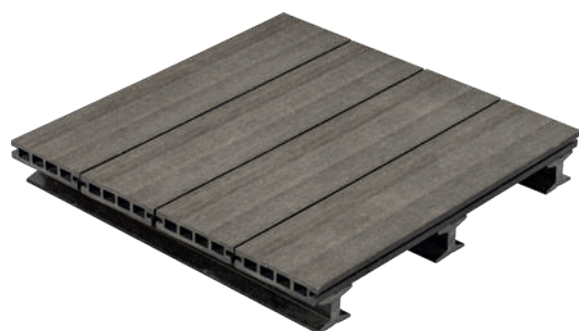

Simulação de aplicação do Maxideck

## MINIDECK

Barra | Bar | Barra 240 x 5,8 x 2,4 cm



Minideck Imbuia | Brazilian Walnut | Imbuia  
Cód. | Code - 21348

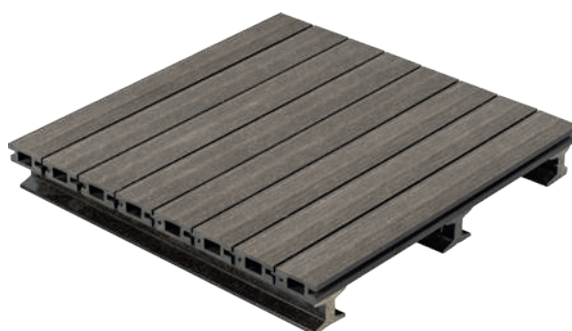

Simulação de aplicação do Minideck

- Fácil de instalar | Easy to install | Fácil de instalar
- Não necessita de pintura | No painting needed | No requiere pintura
- Uso interno e externo | Internal and external use | Uso interno e externo

Barrotes | Bars | Barrotes  
240 x 5,4 x 4,4cm

Clipes de Fixação  
Fixation Clips  
Clip de Fijación



Barrote | Bar | Barrote  
Imbuia | Brazilian Walnut | Imbuia  
Cód. | Code - 26185

Grampo | Clip | Clip  
Imbuia | Brazilian Walnut | Imbuia  
Cód. | Code - 27970

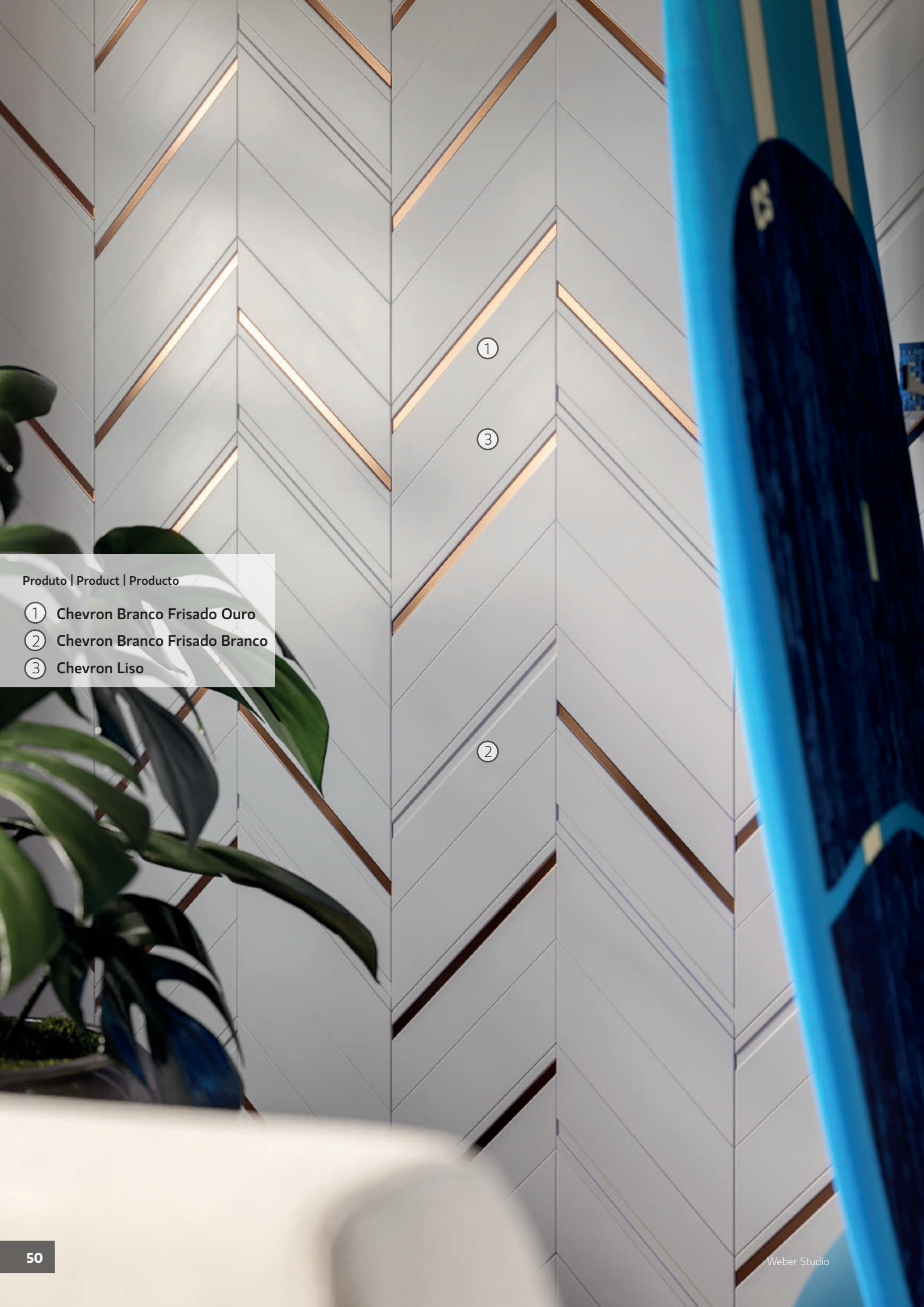

Produto | Product | Producto

- ① Chevron Branco Frisado Ouro
- ② Chevron Branco Frisado Branco
- ③ Chevron Liso



# Coleção Chevron

PRODUTO  
SANTALUZIA

Peças com 350 x 70 x 8 mm

É possível encontrá-lo há milênios, mas foi por meio da grife italiana Missoni que o grafismo Chevron, o popular "espinha de peixe", imortalizou-se no imaginário de gerações e gerações adiante. A famosa paginação em zigue-zague é apenas uma das possibilidades da nova coleção de revestimentos de parede da Santa Luzia, feito de PS reciclado e disponíveis em oito cores.

*It has been around for millennia, but it was through the Italian brand Missoni that the Chevron graphics, the popular "fishbone", immortalized itself in the imagination of generations and generations ahead. The famous zigzag pagination is just one of the possibilities of Santa Luzia's new collection of wall coverings, made from recycled Polystyrene and available in eight colors.*

*Es posible encontrarlo durante milenios, pero fue a través de la marca italiana Missoni que el gráfico de Chevron, o la popular "aleta de pez", se immortalizó en la imaginación de generaciones y generaciones. La famosa formación en zigzag es solo una de las posibilidades de la nueva colección de revestimientos de paredes de Santa Luzia, hecha de PS reciclado y disponible en ocho colores.*

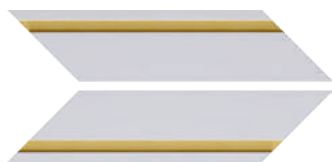

**CHEVRON**  
**Branco Frisado Ouro**  
White Milled Gold  
Blanco con friso oro  
Cod: 21346

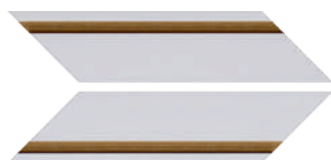

**CHEVRON**  
**Branco Frisado Cobre**  
White Milled Copper  
Blanco con friso Cobre  
Cod: 21347

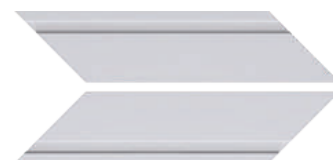

**CHEVRON**  
**Branco Frisado Branco**  
White Milled White  
Blanco con friso Branco  
Cod: 21345



**CHEVRON**  
**Preto Liso**  
Smooth Black  
Negro Liso  
Cod: 21344

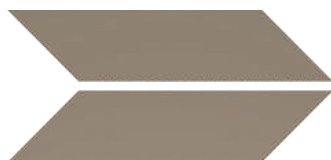

**CHEVRON**  
**Rupestre Liso**  
Smooth Rock  
Rupestre Liso  
Cod: 21342

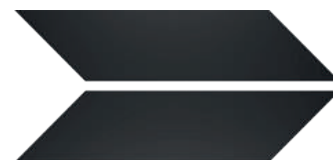

**CHEVRON**  
**Cinza Liso**  
Smooth Graphite Gray  
Gris Grafito  
Cod: 21343

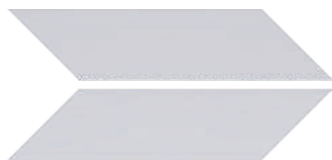

**CHEVRON**  
**Branco Liso**  
Smooth White  
Blanco liso  
Cod: 21340

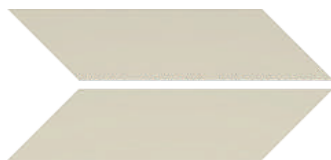

**CHEVRON**  
**Algodão Egípcio Liso**  
Smooth Egyptian Cotton  
Algodón Egípcio liso  
Cod: 21341

## Aplicações

A coleção Chevron traz diferentes possibilidades ao seu ambiente, com seu formato angular, pode se criar padrões modernos que deixarão seus ambientes luxuosos.

*The Chevron collection brings different possibilities to your environment, with its angular shape, you can create modern patterns that will make your environments luxurious.*

*La Colección Chevron trae diferentes posibilidades de creación en su ambiente, con su formato angular permite hacer combinaciones modernas que dejaran sus ambientes lujosos*

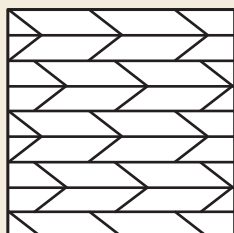

**Chevron Seta**  
Indicator Chevron  
Chevron Zeta

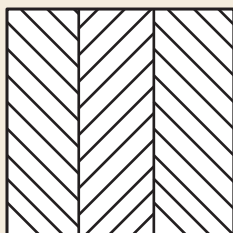

**Chevron Flecha**  
Arrow Chevron  
Chevron Flecha

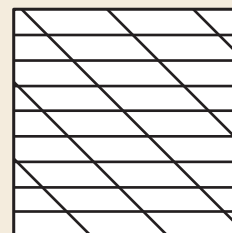

**Chevron Diagonal**  
Diagonal Chevron  
Chevron Diagonal

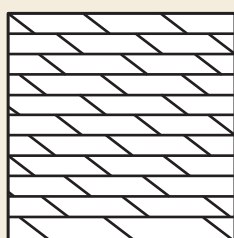

**Chevron Desalinado**  
Messy Chevron  
Chevron Desalineado

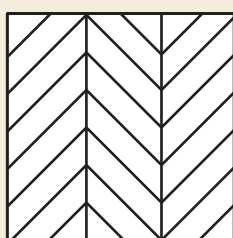

**Chevron Tradicional**  
Traditional Chevron  
Chevron Tradicional

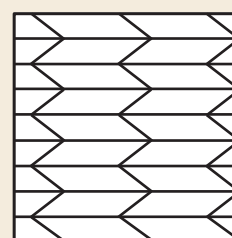

**Chevron Seta Alinhada**  
Aligned Indicator Chevron  
Chevron Zeta Alineado

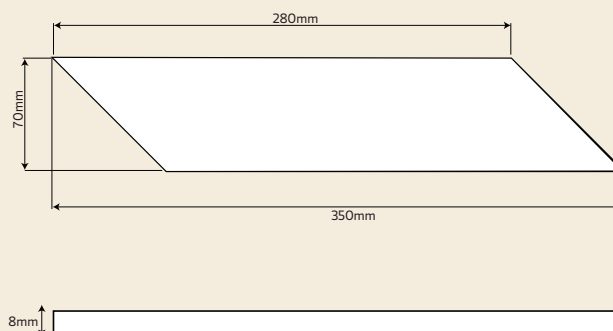



Produto | Product | Producto

- ① Chevron Branco Frisado Ouro
- ② Chevron Branco Frisado Branco
- ③ Chevron Liso Branco





Produto | Product | Producto

① Chevron Liso Ruprestre





Produto | Product | Producto

- ① 547 RP/BR
- ② Woodpanel Branco



②

①



Produto | Product | Producto

- ① WoodPanel Castanho
- ② WoodPanel Castanho Claro
- ③ WoodPanel Castanho Escuro



Ideal para quem gosta de renovar a casa no melhor estilo faça-você-mesmo, a Wood Panel é composta por placas de madeira oriunda de Pinus reflorestado em seis cores com diferentes acabamentos. A instalação é fácil em paredes inteiras, painéis de TV e cabeceiras de cama, por exemplo, tornando ambientes mais aconchegantes.

*Ideal for those who like to renovate the house in the best do-it-yourself style, the Wood Panel Collection is composed of wooden panels in six colors*

*Ideal para quienes gustan de renovar la casa en el mejor estilo DIY (bricolaje), el Wood Panel se compone de tablas de madera en pino reflorestado, en seis colores, con diferentes acabados. La instalación es fácil en paredes enteras, paneles de TV y cabeceras, por ejemplo, haciendo que los ambientes sean más acogedores. Placas de pino reforestado en seis colores.*

## **WOODPANEL Azul**

Blue | Azul

Cód. | Code - 21391



## **WOODPANEL Branco**

White | Blanco

Cód. | Code - 21364



## **WOODPANEL Preto**

Black | Negro

Cód. | Code - 21395



## **WOODPANEL Castanho Escuro**

Dark Brown | Castaño Oscuro

Cód. | Code - 21394



## **WOODPANEL Castanho**

Brown | Castaño

Cód. | Code - 21393



## **WOODPANEL Castanho Claro**

Light Brown | Castaño Claro

Cód. | Code - 21392



## Applications

A beleza rustica da madeira que possibilita a criação de painéis em diversos ambientes, com padrões diferenciados agregando personalidade ao seu lar.

*The Chevron collection brings different creation possibilities to your environment, with its angular shape, you can create modern patterns that will make your environments luxurious.*

*La belleza de la madera rustica que possibilita la creacion de paneles en diferentes ambientes , con diversas combinaciones agregando personalidad al espacio.*

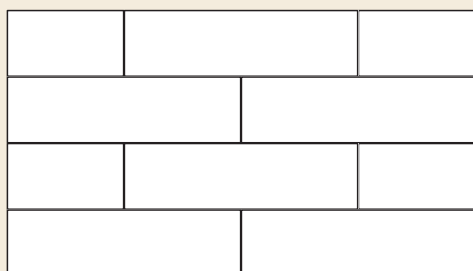

**Painel Horizontal**

Horizontal Panel  
Panel Horizontal

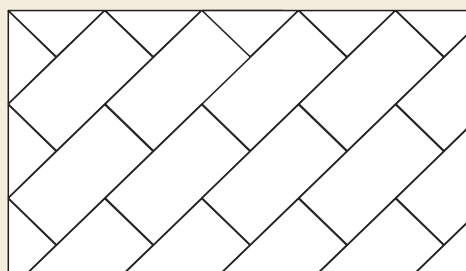

**Painel Diagonal**

Diagonal Panel  
Panel Diagonal

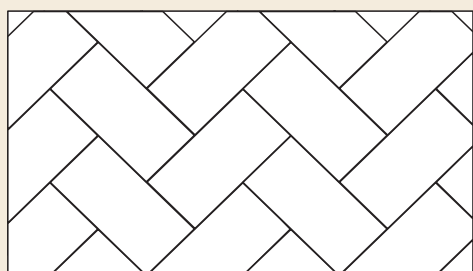

**Painel Espinha-de-Peixe**

Herringbone Panel  
Panel Espina de Pez

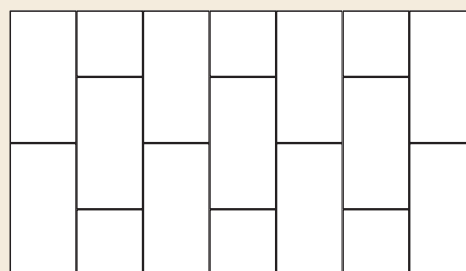

**Painel Vertical**

Vertical Panel  
Panel Vertical

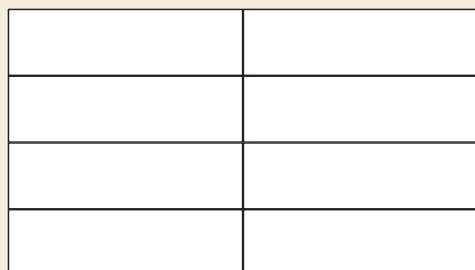

**Painel Alinhado**

Aligned Panel  
Panel Alineado

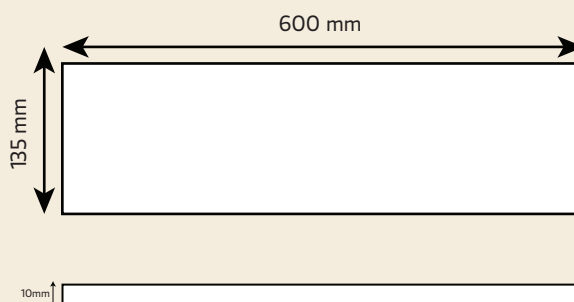





Produto | Product | Producto

- ① WoodPanel Azul
- ② Ecodeck Maxi

①

②



# Acessórios

Accessories | Accesorios

A Santa Luzia desenvolveu soluções completas para instalação e complementação de seu mix de perfis e revestimentos, afinal, não basta um rodapé ser bonito se o adesivo que vai fixá-lo não for de qualidade. A empresa desenvolveu uma abrangente coleção de fixadores como o Super Adesivo (branco ou incolor), Calafetador, Colas Convencional e Instantânea e Fita Dupla Face, facilitando a vida do instalador. O acabamento perfeito é garantido por meio das Massas Premium e Terminais de Acabamento (centro, topo, interno e externo) para ocultar emendas, cortes e junções.

*Santa Luzia has developed complete solutions for installing and complementing its mix of profiles and wall coverings, after all, it is not enough for a baseboard to be beautiful if the adhesive that is going to fix it is not of great quality. The company has developed a comprehensive collection of fasteners with Super Adhesive (white or colorless), Sealants, Conventional and Instant Glues and Double Sided Tape, making the installer's life easier. The perfect finish is guaranteed with the use of Premium Caulk and/or Finishing Terminals (center, top, internal and external) to hide seams, cuts and joints.*

*Santa Luzia ha desarrollado soluciones completas para instalar y complementar su mix de perfiles y revestimientos, después de todo, no es suficiente para que un pie zócalo sea hermoso si el adhesivo que lo arreglará no es de calidad. La compañía ha desarrollado una completa colección de fijadores con súper adhesivo (blanco o incoloro), Calafetador, colas Convencionales e instantaneas y cintas bifaz, facilitando la vida del instalador. La terminación perfecta está garantizada a través de las Masas Premium y Terminales de terminación (centro, superior, interno y externo) para ocultar costuras, cortes y juntas.*

## SUPER ADESIVO

Heavy Duty Adhesive | Super Pegatina



Super Adesivo |  
Heavy Duty Adhesive  
Super Pegatina

Embalagens | Package | Embaje:  
Branco | White | Blanco - 400g  
Cod. Code: 28934  
Incolor | Colorless | Incolora - 280g  
Cod. Code: 21267

## COLA SUPER INSTANTÂNEA

Instant Glue | Pegamento Instantâneo



**EXCLUSIVO PARA USO EM  
PERFIS DE POLIESTIRENO  
SANTA LUZIA.**

**EXCLUSIVE FOR SANTA LUZIA'S  
POLYSTYRENE PROFILES ONLY**

**EXCLUSIVO PARA USO EN PERFILES  
DE POLIESTIRENO SANTA LUZIA.**

Cola Super Instantânea  
Embalagem | Package | Embaje:  
100g  
Cod. Code: 21211

## COLA

Glue | Pegamento



Cola | Glue | Pegamento  
Embalagens | Package | Embaje:  
400g - Cod. Code: 21073  
1 Kg - Cod. Code: 26061  
3 Kg - Cod. Code: 28647  
5 Kg - Cod. Code: 21311



## CALAFETADOR BASE D'ÁGUA

Caulk | Cafafeteador



Calafetador  
Caulk  
Calafeteador  
Embalagens | Package | Embaje  
400g  
Cod. Code: 28988

- **FLEXÍVEL**
- **NÃO AMARELA**
- **CONTÉM FUNGICIDA**
- **USO INTERNO E EXTERNO**

- Flexible
- Non Yellowing
- Contains Fungicide
- Internal and external use
- Flexible
- No Amarillo
- Contiene Fungicida
- Uso interno y externo



## MASSA PREMIUM

Caulk Santa Luzia | Masilla Santa Luzia

### SÃO 15 CORES PARA UM PERFEITO ACABAMENTO

15 colors for a perfect finish | 15 colores para un acabado perfecto



Branca 90g e 340g  
White | Blanco 90g and 340g

Coloridas 90g  
Colored | Coloridas 90g

27008 - Branca | White | Blanco - 340 gr | 12 oz - 12 unid. | 12 units | 12 unidades  
27009 - Branca | White | Blanco - 90 gr | 3,14 oz - 36 unid. | 36 units | 36 unidades  
27010 - Preta | Black | Negro - 90 gr | 3,14 oz - 36 unid. | 36 units | 36 unidades  
27011 - Preta | Black | Negro - 90 gr | 3,14 oz - 6 unid. | 6 units | 6 unidades  
27012 - Ouro | Gold | Oro - 90 gr | 3,14 oz  
27013 - Prata | Silver | Plata - 90 gr | 3,14 oz  
27014 - Cobre | Cooper | Cobre - 90 gr | 3,14 oz  
27015 - Carvalho Prata | Silve OAK | Carvalho Plata - 90 gr | 3,14 oz  
27016 - Ipê Escuro | Dark Ipe | Ipe Oscuro - 90 gr | 3,14 oz  
27089 - Branca | White | Blanca - 90 gr | 3,14 oz  
27723 - Cinza Glacial | Glacial Gray | Gris Glacial - 90 gr | 3,14 oz  
27724 - Cinza Titanium | Titanium Gray | Gris Titano - 90 gr | 3,14 oz  
28979 - Tijolo | Brick | Ladrillo - 90 gr | 3,14 oz  
28978 - Vermelho Escuro | Dark Red | Rojo Oscuro - 90 gr | 3,14 oz  
28975 - Eucalipto | Eucalyptu | Eucalipto - 90 gr | 3,14 oz  
28977 - Rupestre | Rock | Rupestre - 90 gr | 3,14 oz  
28974 - Melodia do Mar | Melody of the Sea | Moldia del Mar - 90 gr | 3,14 oz  
28976 - Pistache | Pistachio | Pistacho - 90 gr | 3,14 oz

## FITA DUPLA FACE

Double sided tape | Cinta Doble Cara

Fita de Espuma de Poliuretano

Polyurethane foam tape

Cinta de espuma de poliuretano



Caixas de 2 e 10 metros  
2 or 10 m boxes  
Cajas de 2 o 10 metros  
2 - Cod. | Code: 28202  
10 - Cod. | Code: 28201

## CLIP ECODECK

Ecodeck Clip | Clip Ecodeck

3 cores - Imbuia

3 colors - Brazilian Walnut

3 colores - Imbuia



Pacote com 30 unidades  
Package with 30 units  
Embaje con 30 unidades  
Cod. | Code: 27970

## BUCHA T

T Bracket | Tarugo T

Acompanha prego de aço 13x15 sem cabeça

Comes with headless steel nails 13x15

Incluye clavo de acero sin cabeza 13x15



Pacote com 30/50/100 unidades  
Package with 30/50/100 units  
Embaje con 30/50/100 unidades  
30 - Cod. | Code: 26039  
50 - Cod. | Code: 26040  
100 - Cod. | Code: 26041

# Acessórios

Accessories | Accesorios

## TERMINAL DE TOPO

Top corner guard | Guardia de topo



PRODUZIDO EM PU (POLIURETANO) RECICLADO

### NOVAS ALTURAS

Para rodapés com 20 e 25 cm de altura.

#### MARCAÇÕES PARA CORTE CONFORME O RODAPÉ

Cutting marking according to the baseboard.  
Marca de corte según el zócalo.

RP	TR
50mm	55mm
70mm	75mm
80mm	85mm
100mm	105mm
150mm	155mm

RP - Rodapé | Baseboard | Zócalo  
TR - Terminal | corner guard | Guardia

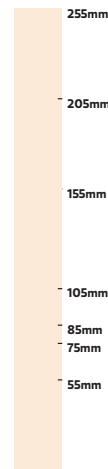

255 mm - 10 1/16"  
20 mm  
13/16"

Pacotes com 04 unidades  
Package with 04 units  
Embaje con 04 unidades  
155 mm - Cod. | Code: 27925  
205 mm - Cod. | Code: 21350  
255 mm - Cod. | Code: 21351

## TERMINAIS DE ACABAMENTO

Finishing Corner | Guardia de topo

Terminal para Canto Externo  
Outer Corner Guard  
Guardia de Esquina Exterior

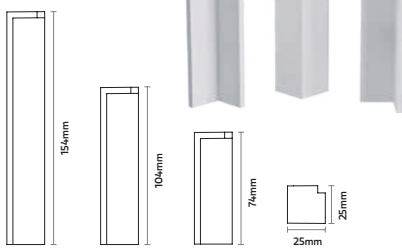

Terminal de Centro  
Corner Guard  
Guardia de Centro

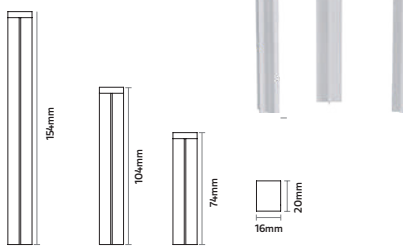

Terminal para Canto Interno  
Inner Corner Guard  
Guardia de Esquina Interior

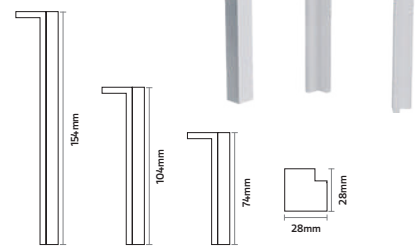

## Cores | Colors | Colores

**Coloridos | Colored | Coloridos: 15 cm**

- 29040 - Rupestre | Rock | Rupestre
- 29037 - Eucalipto | Eucalyptus | Eucalipto
- 29038 - Melodia do Mar | Melody of the Sea | Melodia del Mar
- 29030 - Tijolo | Brick | Ladrillo
- 29041 - Vermelho Escuro | Dark Red | Rojo Oscuro
- 29039 - Pistache | Pistachio | Pistacho

**Branco | White | Blanco**

- 28752 - Branco | White | Blanco - 7 cm
- 28593 - Branco | White | Blanco - 10 cm
- 28753 - Branco | White | Blanco - 15 cm

**Coloridos | Colored | Coloridos: 15 cm**

- 29035 - Rupestre | Rock | Rupestre
- 29032 - Eucalipto | Eucalyptus | Eucalipto
- 29033 - Melodia do Mar | Melody of the Sea | Melodia del Mar
- 29029 - Tijolo | Brick | Ladrillo
- 29036 - Vermelho Escuro | Dark Red | Rojo Oscuro
- 29034 - Pistache | Pistachio | Pistacho

**Branco | White | Blanco**

- 28756 - Branco | White | Blanco - 7 cm
- 28594 - Branco | White | Blanco - 10 cm
- 28757 - Branco | White | Blanco - 15 cm

**Coloridos | Colored | Coloridos: 15 cm**

- 29045 - Rupestre | Rock | Rupestre
- 29042 - Eucalipto | Eucalyptus | Eucalipto
- 29043 - Melodia do Mar | Melody of the Sea | Melodia del Mar
- 29031 - Tijolo | Brick | Ladrillo
- 29046 - Vermelho Escuro | Dark Red | Rojo Oscuro
- 29044 - Pistache | Pistachio | Pistacho

**Branco | White | Blanco**

- 28754 - Branco | White | Blanco - 7 cm
- 28595 - Branco | White | Blanco - 10 cm
- 28755 - Branco | White | Blanco - 15 cm

## Cores sob encomenda | Customized colors | Colores hechos a pedido: Cinzas | Grays | Grises

**Cinza Glacial e Cinza Titanium | Glacial Gray and Titanium Gray | Gris Glacial y Gris Titano**

- 21643 - Cinza Glacial | Glacial Gray | Gris Glacial - 7 cm
- 21645 - Cinza Glacial | Glacial Gray | Gris Glacial - 10 cm
- 21614 - Cinza Glacial | Glacial Gray | Gris Glacial - 15 cm
- 21644 - Cinza Titanium | Titanium Gray | Gris Titano - 7 cm
- 21646 - Cinza Titanium | Titanium Gray | Gris Titano - 10 cm
- 21616 - Cinza Titanium | Titanium Gray | Gris Titano - 15 cm

- 21639 - Cinza Glacial | Glacial Gray | Gris Glacial - 7 cm
- 21641 - Cinza Glacial | Glacial Gray | Gris Glacial - 10 cm
- 21612 - Cinza Glacial | Glacial Gray | Gris Glacial - 15 cm
- 21640 - Cinza Titanium | Titanium Gray | Gris Titano - 7 cm
- 21642 - Cinza Titanium | Titanium Gray | Gris Titano - 10 cm
- 21613 - Cinza Titanium | Titanium Gray | Gris Titano - 15 cm

- 21647 - Cinza Glacial | Glacial Gray | Gris Glacial - 7 cm
- 21649 - Cinza Glacial | Glacial Gray | Gris Glacial - 10 cm
- 21617 - Cinza Glacial | Glacial Gray | Gris Glacial - 15 cm
- 21648 - Cinza Titanium | Titanium Gray | Gris Titano - 7 cm
- 21650 - Cinza Titanium | Titanium Gray | Gris Titano - 10 cm
- 21618 - Cinza Titanium | Titanium Gray | Gris Titano - 15 cm



# SUA CALCULADORA DE RENDIMENTOS

Criamos uma calculadora de rendimentos, onde você pode verificar qual a quantidade de material será usada na instalação dos produtos, no seu ambiente.

Utilizando as especificações de sua obra, você consegue ter a indicação de qual o melhor acessório da Santa Luzia para esse processo.

Acesse o Código QR e facilite sua compra!



## ACOMPANHE PASSO A PASSO **COMO É FÁCIL INSTALAR** OS PRODUTOS SANTA LUZIA



Leia o Código QR e acompanhe o canal





### Matriz | Headquarter | Sede

Rua Heriberto Efftting, 555 - Bairro Santa Luzia  
CEP 88750-000 - Braço do Norte - SC - Brasil

### Showroom Brasil

Edifício Thera Offices Faria Lima - Conj. 1503  
Rua Pais Leme, 215 - Pinheiros - CEP 05424-150  
São Paulo - SP - Brasil

Telefone/Phone/Teléfono: +55 (48) 3651-1300



Conheça todos os nossos produtos em:  
Find all our products:  
Conozca todos nuestros productos:

[www.industriasantaluzia.com.br](http://www.industriasantaluzia.com.br)

 /santaluziarodapes

 @santa.luzia

 /industria.santaluzia

 [blog.santaluziamolduras.com.br](http://blog.santaluziamolduras.com.br)



Conheça todos os nossos produtos em:  
Find all our products:  
Conozca todos nuestros productos:

[www.santaluzia.com.ar](http://www.santaluzia.com.ar)

 /santaluziarodapes

 @santaluziaarg

 /industria.santaluzia



Conheça todos os nossos produtos em:  
Find all our products:  
Conozca todos nuestros productos:

[www.santaluziamouldings.eu](http://www.santaluziamouldings.eu)

 /santaluziarodapes

 @santaluziamouldings.eu

 /santaluziamouldings.eu

 [blog.santaluziamouldings.com](http://blog.santaluziamouldings.com)